

"Dog Tank"™

Water Management System
by Basement Technologies®



Basement Technologies
The Basement Specialists™
Basement Waterproofing

The "Dog Tank"™ by Basement Technologies®, is designed to meet the most stringent company and industry standards, while providing an effective alternative for high volume sump pump drainage discharge issues. Basement Technologies® waterproofing system comes with a lifetime warranty, stating water will not get into the basement in the areas treated. Most systems require a pumping unit, and that water is usually placed in the yard. There are few water management drywell systems that are infallible, but this system is most likely to be successful in certain applications.

Placed underground, Basement Technologies® Dog Tank™ will hold approximately 31 ft³ or 224 gallons of water, plus there are 6 inches of stone underneath the Dog Tank™ with approximately a yard of stone on the sides and, if the surrounding soil porosity allows the water to drain into the area around the Dog Tank™, there's less of a chance of the water getting onto the surface.

Multiple Dog Tanks can be set up and tied together under the ground for larger water capacity issues and needs.

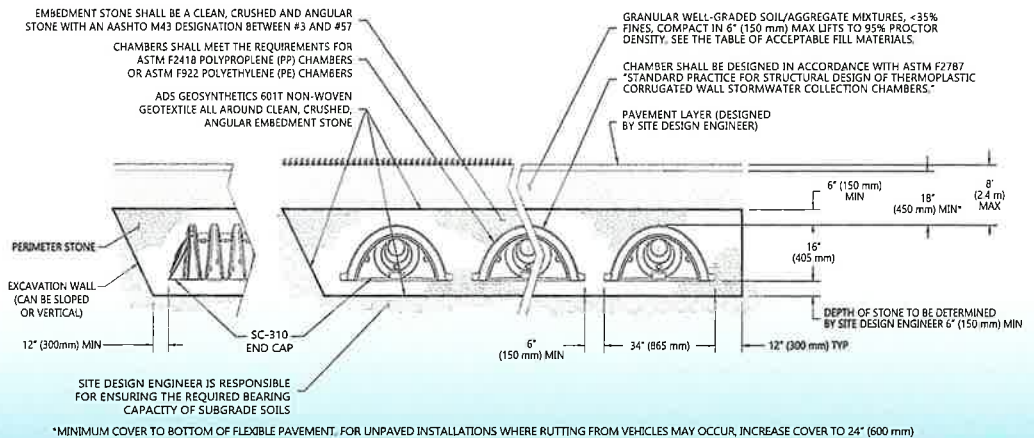
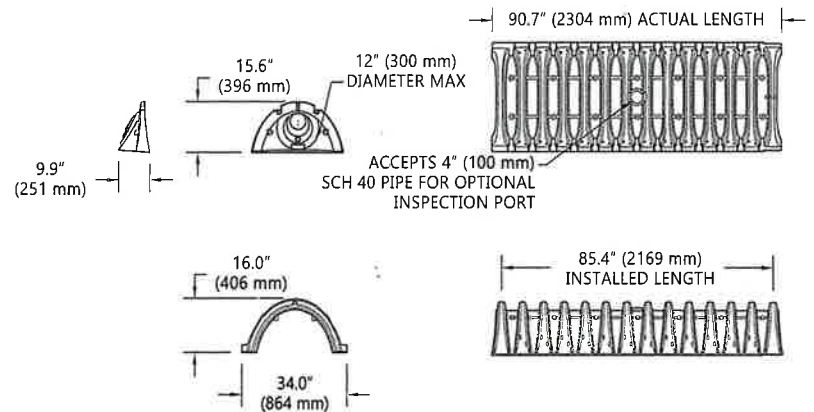

STORMTECH CHAMBER NOMINAL SPECIFICATIONS (NOT TO SCALE)

Size (L x W x H)
85.4" x 34.0" x 16.0"
2,170 mm x 864 mm x 406 mm

Chamber Storage
14.7 ft³ (0.42 m³)

Min. Installed Storage*
31.0 ft³ (0.88 m³)

Weight
37.0 lbs (16.8 kg)

1-800-BUSY DOG®

"Where design and innovation keys our superior products™"

