

Who We Are

Basement Technologies® is the fastest growing basement waterproofing dealer network in the world. Our unique working "model" in the northeast allows our dealers to follow and be able to operate their prospective companies after ours. We proudly present our existing dealer family and, as we continue to grow, watch for new additions to our family in your area.

1-800-Busy-Dog Basement Technologies® is our "model" local company which services homes and businesses in Massachusetts, New Hampshire, and Rhode Island. All dealers use Basement Technologies® as the "role model" for operating their own local Basement Technologies dealership.

We design, manufacture, supply and install all of our own proprietary patented products. Our network of dealers covers the U.S. and Canada. All dealers are certified and licensed by our corporate office. Our certified licensed dealers adhere to our rigid standards for quality installations, products, and customer service. Our products are all custom tailored to each basement situation, unlike many "cookie cutter" systems on the market today.

We have 16 federal patents, 11 patents pending and over 30 federal registered trademarks. We only allow our trained and licensed dealers to utilize and install our patented products.

No one tries harder than Basement Technologies® to provide superlative basement waterproofing while continuously upgrading the industry's standards.

We train all new and existing dealers at our Basement and Crawl space training center located at our flagship company in Massachusetts.

At our training center we maintain a complete inventory of products and supplies. It is the home-base for training our new dealers and employees in state-of-the-art basement waterproofing techniques. Customers are presented our "done once - done right" solutions from only fully-trained and experienced technical estimators and installation crews.



Dealer training at our International training center where we teach our state-of-the-art basement waterproofing techniques.



We're Here For You



Call 1-800-Busy-Dog (287-9364) or e-mail us at info@1800busydog.com or customer care@1800busydog.com. Please visit our website at www.1800busydog.com.

About Our Founder

James Pratt, Founder and President of our two companies, 1-800-Busy-Dog Basement Technologies® and Basement Technologies, Inc.®, has over 30 years of experience in basement waterproofing, structural repair and remodeling. James was trained in marine and fluid technologies and has several degrees from the prestigious Florida Institute of Technology. He has been instrumental in changing the way the waterproofing industry approaches water problems and has literally reinvented the way basement waterproofing is being done today. James has devoted much of his time and energy to research and development. As a result, his patented products and systems are being installed by dealers throughout the world in thousands of homes. Thanks to James' "hands-on" approach, insisting on complete follow through on each project, quality installations and service, homeowners are assured their basement waterproofing project will be done with professionalism.

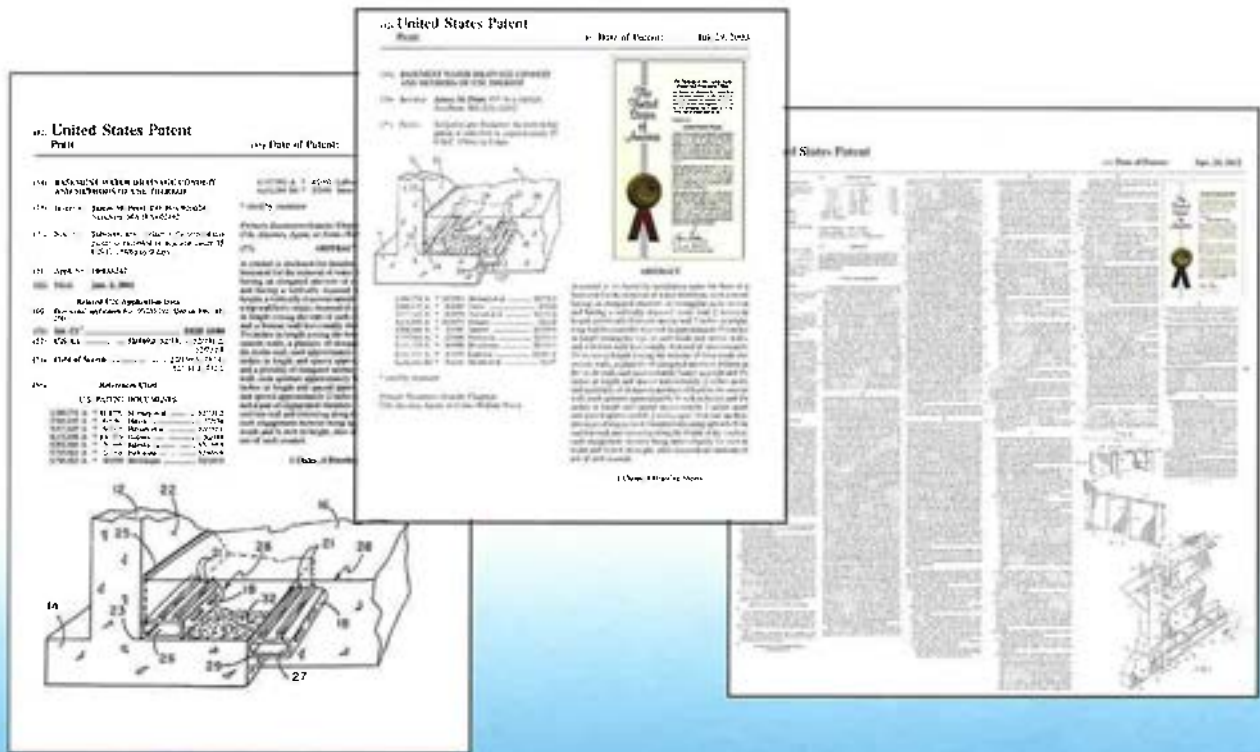

www.1800busydog.com®



AirMop IV[®] Compact

Basement & Crawl Space Dehumidifier



FEATURES

- Built-in automatic digital control with display.
Can be set up for dehumidification and ventilation or zoning.
- Front mount control
- ½" EPS cabinet insulation
- Air discharge orientation at end of cabinet
- Washable MERV 8 filter (part number 5695) and 8" diameter inlet/outlet duct collars
- R410A refrigerant
- Corrosion-resistant aluminum coils
- 8' power cord (plug type); hardwire option not available
- 10°F–30°F discharge air temperature rise
- ¾" MNPT Threaded drain connection with adapters for threaded connection for plastic hose included
- 10' drain tubing
- 5-year warranty

SPECIFICATIONS

Capacity	@ 80°F/60% RH @ 73°F/60% RH	70 ppd 53 ppd
Energy Factor kW-h	@ 80°F/60% RH @ 73°F/60% RH	2.1 L/kW-h 1.8 L/KW-h
Airflow @ varying E.S.P. (external static pressure - dry coil)	0.0" w.c. 0.2" w.c. 0.4" w.c.	200 CFM 170 CFM 140 CFM
Voltage, phase, frequency	120VAC, 1 phase, 60 Hz	
Current draw⁽³⁾	5.8 Amps	
Noise	53 dBA ducted	
Dimensions (cabinet only)⁽⁴⁾	Width: 12½", Height: 12½", Length: 25"	
Unit Weight Shipping Weight	56 lbs. 72 lbs.	
Inlet air operating conditions during	Dehumidification:	50°F–104°F, 40°F dew point min.
	Ventilation:	40°F–140°F, 0%–99% RH (non-condensing)

⁽³⁾Rated capacity, energy factor and current draw measured at 80°F/60% RH inlet air at 0.0 ESP.
⁽⁴⁾Height does not include adjustable feet. The width excludes the filter doors and length excludes the duct collars.

Designed to control excess moisture and humidity in crawl spaces. Along with optional hanging and duct kits, allows it to fit where no other dehumidifier can. For professional-grade efficiency and effectiveness, the AirMop IV[®] Compact is your dehumidifier of choice.

- Provides high-capacity water removal at 70 pints per day*
*Measured at 80° f and 60% rh
- Effective in medium-sized spaces up to 1600 ft.
- A MERV 8 filter comes standard with the AirMop IV[®] Compact, keeping the unit operating at peak efficiency for longer
- Automatically restarts at the original setting after a power outage
- Optional accessories include hanging kits, duct kits, and condensate pumps for flexible installation and professional-grade moisture removal

The AirMop IV[®] Compact will control excess humidity and help prevent:



Mold – Mold spores grow in moist areas and can cause allergy symptoms and respiratory issues.



Dust Mites – Humid air helps dust mites thrive, which is also a cause of allergy flare-ups.

Other health concerns that the AirMop IV[®] Compact can help prevent the proliferation of:



Viruses



Bacteria



Fungi



Mildew

Your whole-home environment is only as healthy as your basement. Use the AirMop IV[®] Compact to soak up your basement's moist air to stop humidity control issues from arising.

1-800-BUSY DOG[®]



AirMop IV® Full Size

Basement & Crawl Space Dehumidifier

**1-800-Busy Dog
Basement
Technologies**
The Basement Specialists™
Basement Waterproofing

FEATURES

- Built-in automatic digital control with display.
Can be set up for dehumidification and ventilation or zoning.
- Control mounting option is field-interchangeable from top to front
- ½" EPS cabinet insulation
- Top or end air discharge orientation
- 10" diameter inlet/outlet duct collars
- Backdraft damper at outlet
- R410A refrigerant
- Corrosion-resistant aluminum coils
- 8' power cord
- 10°F–30°F discharge air temperature rise
- ¾" MNPT Threaded drain connection with threaded barbed fitting included
- 5-year warranty



SPECIFICATIONS

Capacity	@ 80°F/60% RH @ 73°F/60% RH	100 ppd 85 ppd
Energy Factor kW-h	@ 80°F/60% RH @ 73°F/60% RH	2.6 L/kW-h 2.35 L/kW-h
Airflow @ varying E.S.P. (external static pressure - dry coil)	0.0" w.c. 0.2" w.c. 0.4" w.c.	280 CFM 245 CFM 210 CFM
Voltage, phase, frequency	120VAC, 1 phase, 60 Hz	
Current draw⁽³⁾	6.9 Amps	
Noise	55 dBA ducted	
Dimensions (cabinet only)⁽⁴⁾	Width: 14", Height: 15", Length: 26"	
Unit Weight Shipping Weight	64 lbs. 82 lbs.	
Inlet air operating conditions during	Dehumidification:	50°F–104°F, 40°F dew point min.
	Ventilation:	40°F–140°F, 0%–99% RH (non-condensing)

⁽³⁾Rated capacity, energy factor and current draw measured at 80°F/60% RH inlet air at 0.0 ESP.
⁽⁴⁾Height does not include adjustable feet. The width excludes the filter doors and length excludes the duct collars.

Designed to control excess moisture and humidity in crawl spaces. Along with optional hanging and duct kits, allows it to fit where no other dehumidifier can. For professional-grade efficiency and effectiveness, the AirMop IV® Full Size is your dehumidifier of choice.

- Provides high-capacity water removal at 100 pints per day*
*Measured at 80° f and 60% rh
- Effective in spaces up to 3200 ft.
- A MERV 8 filter comes standard with the AirMop IV® Full Size, keeping the unit operating at peak efficiency for longer
- Automatically restarts at the original setting after a power outage
- Optional accessories include hanging kits, duct kits, and condensate pumps for flexible installation and professional-grade moisture removal

The AirMop IV® Full Size will control excess humidity and help prevent:



Mold – Mold spores grow in moist areas and can cause allergy symptoms and respiratory issues.



Dust Mites – Humid air helps dust mites thrive, which is also a cause of allergy flare-ups.

Other health concerns that the AirMop IV® Full Size can help prevent the proliferation of:



Viruses



Bacteria



Fungi



Mildew

Your whole-home environment is only as healthy as your basement. Use the AirMop IV® Full Size to soak up your basement's moist air to stop humidity control issues from arising.

1-800-BUSY DOG®



ALTERNATOR™

Patented Emergency Discharge

Basement Technologies
The Basement Specialists™
Basement Waterproofing

During the winter months, it can be common to have 1 - 3 feet of snow piled on the lawn. Water from the Water Grabber® is pumped onto the lawn through our patented Freeze Stop™ and Bubbler Pot™ and will melt the snow. Yard floods should not affect your interior dryness, however, it is possible for the exterior flooding to cause other problems:

- Water coming in through the window
- Flooding of lawn
- Ice patches on driveway.

1-800-Busy Dog Basement Technologies® has the Solution! Patented ...

... because no one else thinks like your 1-800-Busy Dog Basement Technologies® Dealer!



The Alternator™ is another reason why 1-800-Busy Dog Basement Technologies® dominates the basement waterproofing industry. We designed this product with the homeowner's needs in mind. Because our only business is your "dry basement".

Often the best laid plans go awry! The pump is able to pump a minimum of 3,000 gallons of water an hour. Mixing this flow with spring melting snow could cause a potential exterior flood. The patented Alternator™ allows you to re-route the discharge point to a more appropriate area if necessary. Our patented Freeze Stop™ guarantees the pump will discharge in freezing conditions and usually this will be enough. However, our patented Alternator™ gives you the emergency option to direct the water to a different area in the yard. The Alternator™ is an exclusive option which perfectly compliments your patented Freeze Stop™ system. Ask your dealer if the Alternator™ system can benefit your yard.

1-800-BUSY DOG®



BASEBOARD AQUA ROUTE®

**Basement
Technologies**
The Basement Specialists™
Basement Waterproofing

The Baseboard Aqua Route® was developed by Basement Technologies® to address specialty floors with very thick, fiber-reinforced rebar or monolithically poured floors. The Baseboard Aqua Route® works very well as long as there are no leaking floor cracks or holes in the middle of the floor. If there are minor cracks, special operations for installation can repair these. The majority of basement water seepage comes from the floor/wall joint. This is due to water pressure in the over dig area outside the foundation walls, Water in this over dig area creates pressure where the foundation footing meets the foundation wall. Water seeks the point of least resistance and therefore, will come in on the joint over the footing and under the foundation wall and then straight to where the floor meets the wall. This is particularly true if there are no floor cracks or penetrations in the cement floor in the basement. (see diagram A)

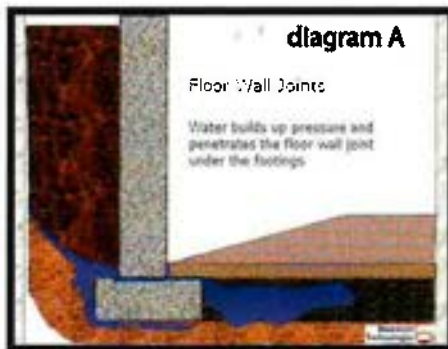

The Baseboard Aqua Route® is made out of a ridged polyvinyl chloride, colored gray to match the concrete on the floor and the foundation wall. A special two-part epoxy is applied to the bottom of Baseboard Aqua Route® to secure it permanently to the concrete floor. This seal is warranted for the lifetime of the structure and is transferable upon sale. The preparation process is critical; scarfing the concrete and then sanitizing the floor makes the epoxy seal virtually impossible to penetrate. Holes are drilled at the floor wall joint. If it is a poured foundation wall, holes are drilled through the foundation at a 45-degree angle downward to the footing. These holes allow the water, that is coming in over the footing and threatening to come onto the floor, to



**Basement
Technologies®
custom
tailors each
Installation.**

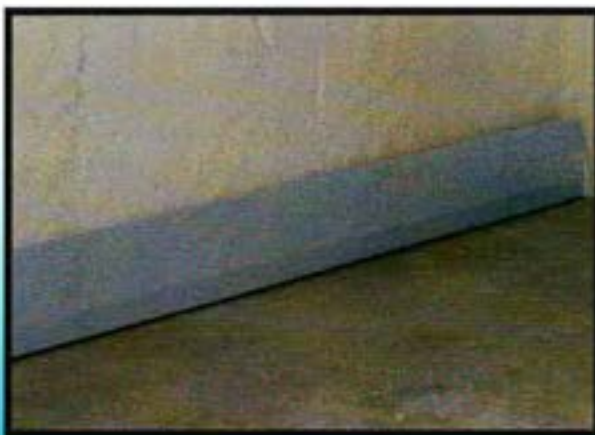

move upward onto the back of the Baseboard Aqua Route® acting similar to a roof "gutter" to remove the water into the Baseboard Aqua Route® towards the pump. If there is a block wall, holes are drilled directly into the block. Special connectors adhere each 8 ft. piece of the Baseboard Aqua Route® together, inside and outside corners are pre-cut (for exact fit) and then 1-1/2" PVC is used to drain from the Baseboard Aqua Route® into the Water Grabber® Bull Dog™.

1-800-BUSY DOG®

"Where design and innovation keys our superior products™"



Copyright © 2011 BBT. All Rights Reserved

BASEBOARD AQUA ROUTE®

**Basement
Technologies**
The Basement Specialists™
Basement Waterproofing



REST EASY.™

These systems come with a lifetime structure warranty and will work very effectively. The system was invented approximately 30 years ago and then improved by Basement Technologies.®

When the basement floor is hard and thick and it is impractical to open the floor, the Baseboard Aqua Route® is the best change of plan. If steel is in the floor (rebar), it may be impractical to cut out the floor around the perimeter. When the footing and the floor are poured at the same time, building engineers and inspectors agree that cutting or opening the floor may cause a structural problem. The footing could crack and "shear" eventually threatening the building's structural integrity.

"There isn't a basement we can not waterproof!"

Basement Technologies® Baseboard Aqua Route® is usually applied if our installation technicians design a:

1. monolithic pour
2. very thick floor without floor cracks, or
3. rebar reinforced floors
4. structural floors

**Improving
basement
waterproofing
from the
ground
up™**



1-800-BUSY DOG®

"Where design and innovation keys our superior products"™

Copyright © 2017 BBT. All Rights Reserved.

BONAIRE

A BREATH OF FRESH AIR!

Reduce humidity, create a healthy home.

Basement Technologies
The Basement Specialists™
Basement Waterproofing

IS YOUR HOME HUMIDITY SICK?

SYMPTOMS...

SUMMER

- Dampness even during dry weather.
- Musty basement odor.
- Mold and mildew build-up.
- Indoor allergic discomfort.
- Moisture and dampness on walls, floors and windows.



WINTER

- Fogged up sweaty, icy windows.
- Water on window sills.
- Home heats up slowly.
- Cold damp basement.



YEAR ROUND

- Rotting window frames and sills.
- Peeling paint.

SOLUTION...

BONAIRE

An easy efficient way to reduce the effect of damaging and uncomfortable humidity in your home. It creates a dynamic air exchange that expels humid indoor air, resulting in a comfortable, dry, healthy living environment.

HOW BONAIRE WORKS

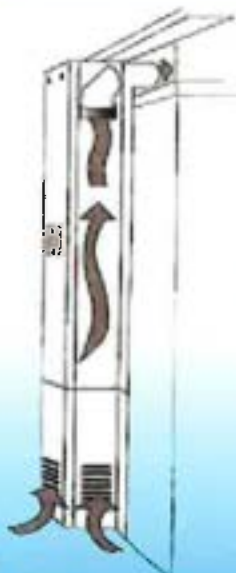

Cool moist air gravitates downward, and condensation is worst at the lowest point in your home i.e. your basement, crawl space or slab floor. BonAire draws moist, stale, contaminated air to the vents via a quiet and powerful fan. This unique revolutionary unit addresses air quality problems where they are created and exists.



The moist air is then vented to the outside of your home through a duct while being replaced with a flow of drier, fresh air drawn downward from the upper levels of your home.



BonAire is controlled by an adjustable humidistat that regulates the air flow. When the desired level of humidity is achieved, the fan speed will automatically reduce. It will resume a higher speed as the humidity level increases. The direct effect is a complete home air exchange occurring anywhere from 6-10 times a day.

BONAIRE VS. CONVENTIONAL DEHUMIDIFIER

MAINTENANCE FREE, EASY OPERATION: Simply set the humidistat to your desired humidity level. The BonAire automatically vents humid air to the outside. There are no heavy buckets of water to empty and no filters to change.

ENERGY EFFICIENT: BonAire runs on only 31 watts of electricity (approx. \$2.00 per month) and plugs into any outlet. Drier air requires less energy to heat in the winter and less energy to cool in the summer, resulting in lower year round energy bills.

ENVIRONMENTALLY FRIENDLY: BonAire contains No CFC's and No Ozone. The fan operates quietly (52 dBA) and there are no contaminated filters to wash or replace. HDS-209 (58 dBA)

LARGE CAPACITY: No need for multiple units. One BonAire will ventilate an area up to 4,000 square feet (basement serviced 1,500 sq.ft.). Yes, one unit will provide fresh air for your entire home! Heavy Duty Model (HDS-209) will do up to 5,500 square feet (basement serviced 2,100 sq.ft.)

AESTHETICALLY PLEASING: BonAire is housed in a compact, discreet, wall mounted, neutral colored cabinet and blends into virtually any home decor.

SUPERIOR AIR QUALITY: BonAire not only reduces humidity in your home but also removes musty basement odors and damp polluted air, replacing stagnant air with fresh, clean air.

PROTECTION AND SECURITY: BonAire reduces condensation and wood rot in window frames and sills. It keeps windows dry and clear. It helps to dry out saturated sheetrock, wood and concrete.

BonAire comes with a **5 year warranty on parts** except outside vent & labor.

BonAire...A Breath of Fresh Air



BonAire, your solution for excess humidity and poor air quality. This innovative ventilation unit provides a healthier home environment by improving the air quality and expelling moist air that nurtures molds and creates condensation.

As Seen on HGTV

WHAT YOU CAN'T SEE CAN HURT YOU!

Air quality ranks high on the list of government environmental concerns.

The air in many homes contains harmful pollutants that are invisible, odorless and not readily detected. These substances can cause health problems such as irritated eyes and nose, headaches, dizziness, chronic fatigue, memory loss, infections, respiratory diseases and more.

Molds usually grow in damp places. Without moisture, they couldn't get started, much less spread. When moisture is present, molds can begin to take hold within 24 hours. Mild molds can cause health problems including sinus and respiratory infections and asthma. More severe molds can develop with lethal effects. Studies show that many of the newer "air-tight" homes are creating a mold epidemic contributing to an increase in respiratory ailments and other serious health problems.

The EPA has written that: "Unless homes are built with special mechanical means of ventilation, homes that are designed to minimize the amount of outdoor air that can leak into and out of the home may have higher pollutant levels than other homes."

A recent article in USA Weekend explained one unfortunate family's battle with a "killer" mold (*Stachybotrys*). "It started with a series of leaks. Within a year, Melinda Ballard's home was quarantined: their three year old son was on daily medication to treat scarred, asthmatic lungs; her husband had lost his memory along with his job."

SOLUTION...

- First, remove or remove pollution sources.
- Second, dilute the concentration of air pollutants and moisture through the increased ventilation of your home.

In other words, install an economical BonAire Ventilation Unit. Your family and home will be glad you did.

BONAIRE HELPS CURE THE "SICK HOME SYNDROME"

- ❌ **MOLDS:** Mold spores can cause serious health problems. The moisture evacuation and air circulation provided by the BonAire Unit reduces the environmental conditions for molds to prosper.
- ❌ **MUSTY ODORS AND MILDEW:** Musty odors and mildew can make any space unusable. BDBT helps create additional living space without the expense of building onto your home.
- ❌ **CHEMICAL POLLUTANTS:** Building materials, home furnishings and wood finishes release formaldehyde and other volatile organic compounds. Released household chemicals are absorbed in moist air and stagnate in your home. The BonAire Ventilation Unit helps remove harmful chemical pollutants from your home.
- ❌ **BIOLOGICAL CONTAMINANTS:** Residues from living organisms such as pollen, fungi, dust mites and animal waste cause infectious diseases, allergic reactions, respiratory ailments and other health problems. BonAire greatly reduces your family's exposure to these contaminants.
- ❌ **DANGEROUS GASES:** Carbon monoxide, radon gas, and natural gas from your appliances can enter your home and accumulate virtually undetected. Gases accumulated in the basement are expelled when BonAire is running.
- ❌ **STRUCTURAL DAMAGE:** Humidity and moisture in general cause serious expensive problems in the home, such as rotting wood, rust and peeling paint. BonAire greatly reduces humidity and its costly, damaging effects in your home.

BonAire...A Breath of Fresh Air



BONAIRE

A BREATH OF FRESH AIR!

Reduce humidity, create a healthy home.

SPECIFICATIONS

Specs. 11" wide x 7" deep

MODEL	Air Flow	Basement		
		Sq. ft.	Sones	Watts
Crawl Space				
Height - 30"				
•UNS 103	200CFM	1800	2.5	.31
•HDS 103	280CFM	2400	3.5	.38
Basement Units				
Standard				
•UNS 209*	200CFM	1500	2.5	.31
Heavy Duty				
•HDS 209*	280CFM	2100	3.5	.38

*Expandable Height to 102"

• US Patent 5,092,520 • CAN Patent 2,018,602

• Entela Cert. #7336

We reserve the right to change specifications without notice.

10 year warranty on all parts except outside vent

Minimal Installation Required:

6" Duct opening to outside to expel moist air.

BonAire is made in Canada by Air Tech Manufacturing, a member of: HRAI-Heating, Refrigeration, and Air Conditioning Institute of Canada Manufacturers Division - Mississauga, Ontario, Canada

BONAIRE ... YOUR PRESCRIPTION FOR A HEALTHY HOME

The BonAire Ventilation Unit will expel many of the dangerous gases that become trapped inside your home due to excess insulation and poor circulation. It reduces relative humidity that worsens the "sick home syndrome."



CUSTOMER COMMENTS

"The best part for me is that all this is done for under \$2.00 per month in electricity."

- D. Power

"Without a doubt, buying a BonAire was the wisest investment we made all year."

- H. Holmstrom

Contact your authorized 1-800-Busy Dog® Basement Technologies dealer

1-800-BUSY DOG®



THE BULLDOG BULKHEAD REPLACEMENT DOOR

1-800-Busy Dog
Basement
Technologies 
The Basement Specialists™
Basement Waterproofing



1-800-BUSY DOG®



Select The Appropriate Style Door

Traditional Doors

ANGLED
Doors
(fit on top of flat
foundations)

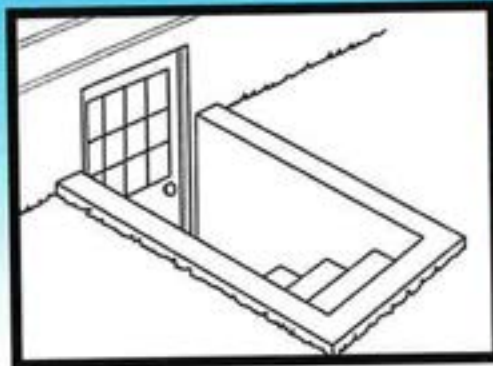

FLAT
Doors
(fit on top of angled
foundations)

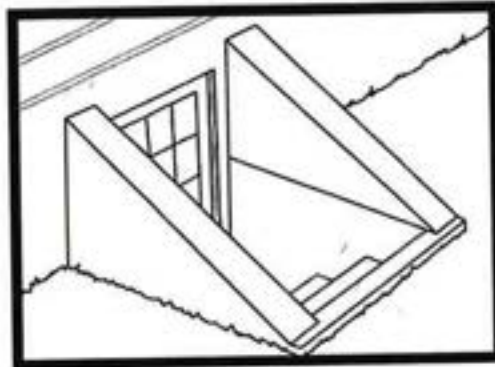

Specialty Doors

"CORNER"
Doors

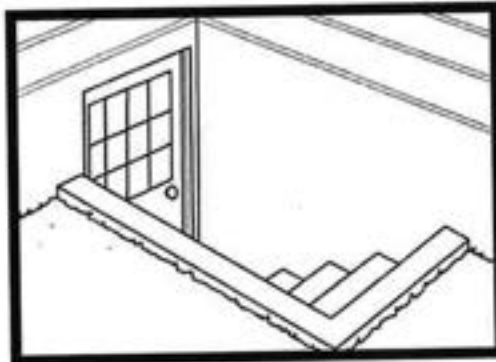

"ALONG-SIDE"
Doors

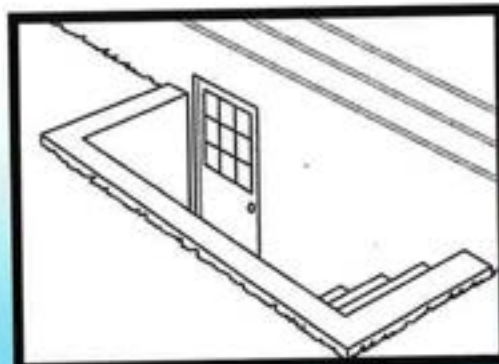

1-800-BUSY DOG®



Features and Benefits

What makes the Bulldog Bulkhead Door the best?

LONG LASTING . . .

Fully-welded joints and multiple coats of primer are just a few of the exclusive features that will ensure years of durable service.

UNLIMITED SIZE SELECTION . . .

Costly extensions and clumsy add-ons are a thing of the past. You get the right door for the job . . . just screw it down, caulk around the outside, give it a coat of paint and you're done!

WEATHER PROOF . . .

Our design of overlapping returns and gutters allows Basement Technologies' doors to shed the worst weather that Mother Nature can dish out.

STRONG . . .

All welded seams, reinforced as needed and the thickest gauge steel you can buy. Able to handle a snow load or heavy use. No more bolts that rust and leak.

IMPROVED SECURITY . . .

Bulldog Bulkhead doors are designed with security in mind. Our fully welded doors feature interior hinges and mounting flanges, as well as an interior slide-bar lock that prevents unwanted intruders from gaining access to your home or business. (Note: Other locking arrangements are also available.)

PAINTABLE . . .

All our doors come primed in a red metal oxide primer. Once installed, they can be painted any color you desire to best match your home or business.

BULLDOG BULKHEAD DOORS FEATURE . . .

- 100% Steel Construction
- Fully-Welded Joints
- Double Torsion Springs on each hinge
- Integrated Hold-Open Bar
- Multi-Coat Rust Inhibitive Primer
- Weather Resistant Design



☆ BULLDOG CERTIFIED ☆

1-800-BUSY DOG®



THE BULLDOG BULKHEAD REPLACEMENT DOOR

1-800-Busy Dog
Basement
Technologies 
The Basement Specialists™
Basement Waterproofing



Any Size... Any Shape
"Your Cellar Entrance Solution"

Any Size... Any Shape...

We can make what you want - to the inch
stock or custom
One door or two?
Inside or outside lock?

1-800-BUSY DOG®



© 2003 Busy Dog Basement Technologies, Inc. All Rights Reserved.

CHEMCRETE

CEMENTITIOUS CRYSTALLINE WATERPROOF SYSTEM
FOR FIELDSTONE, BRICK & POURED FOUNDATIONS

**Basement
Technologies**
The Basement Specialists™
Basement Waterproofing

WARRANTED
NOT to Leak!!!

Basement Technologies Chemcrete has been used for over 10 years in elevator pits and many subgrade high water pressure areas. The expansion and fine tuning of the Chemcrete molecule and application process to treat fieldstone and block walls has been successful for nearly 10 years. However, due to block wall pressure there is a variable on block wall warranty.



1-800-BUSY DOG®



CHEMCRETE

CEMENTITIOUS CRYSTALLINE WATERPROOF SYSTEM
FOR FIELDSTONE, BRICK & POURED FOUNDATIONS

Basement Technologies
The Basement Specialists™
Basement Waterproofing

LEAKING FIELDSTONE, BRICK AND POURED WALLS SEALED FOREVER!!

The Basement Technologies Chemcrete is a one component crystallizing capillary water proofing system composed of many active chemicals. In the presence of moisture, these active chemicals penetrate concrete and react with free lime to produce insoluble crystals that have an affinity to moisture and continue to grow. This crystal growth reduces concrete porosity by blocking capillaries and filling hairline non-structural cracks up to .01 inch caused by contraction or expansion. Quite simply, once applied it continues to grow crystals and stop water. As concrete expands and contracts Chemcrete will do the expansion.

WARRANTED
NOT to Leak!!!

Fieldstone and brick walls offer a beautiful rustic look in older basements, however if they leak or allow rodents into the space then they are officially a problem to be solved.



Mortar joints and voids in these walls lead to nonstop water and or a rodent infestation.



1-800-BUSY DOG®



Who We Are

1-800-Busy-Dog Basement Technologies® is the fastest growing basement waterproofing dealer network in the world, having a working “model” in the northeast where our dealers can model their prospective companies after. We proudly present our existing dealer family and as we continue to grow, watch for new additions to our family in your area.

1-800-Busy-Dog Basement Technologies® and Basement Technologies, Inc.® are our “model” local companies which service homes and businesses in Massachusetts, New Hampshire and Rhode Island. All dealers use Basement Technologies® as the “role model” for operating their own local Basement Technologies dealership.

We design, manufacture, supply and install all our own patented products. Our network of dealers cover the U.S., Canada and the Ukraine. All dealers are “licensed” by our corporate office as a certified “licensed” dealer adhering to our rigid standards for quality installations, products and customer service. Our products are all custom-tailored to each sub-floor situation, unlike many “cookie cutter” systems on the market today.

We have 15 Federal patents, 11 patents pending and over 30 Federal registered trademarks, and we only allow our trained and licensed dealers to utilize and install our patented products.

No one tries harder than 1-800-Busy-Dog Basement Technologies® to provide superlative basement waterproofing and continually upgrades the industry’s standards.

With our flagship company in Massachusetts, Rhode Island and New Hampshire, we train all new and existing dealers at our training center. Our basement and crawl space training center maintains a complete inventory of products and supplies. It is the home-base for training our new dealers and employees in state-of-the-art basement waterproofing techniques. Customers are presented our “done once – done right” solutions from only fully-trained and experienced technical estimators.



**Dealer training
at our interna-
tional training
center where
we teach our
state-of-the-art
basement
waterproofing
techniques.**



We're Here For You



1-800-Busy-Dog Basement Technologies® has dealers throughout the U.S., Canada and Ukraine. All dealers use 1-800-Busy-Dog Basement Technologies® as their model company for their businesses.

Call 1-800-Busy-Dog (287-9364) or e-mail us at info@basementtechnologies.com. Please visit our website at www.basementtechnologies.com.

About Our Founder

James Pratt, Founder and President of our two companies, 1-800-Busy-Dog Basement Technologies® and Basement Technologies, Inc.®, has over 30 years of experience in basement waterproofing, structural repair and remodeling. James was trained in marine and fluid technologies and has several degrees from the prestigious Florida Institute of Technology. He has been instrumental in changing the way the waterproofing industry approaches water problems and has literally reinvented the way basement waterproofing is being done today. James has devoted much of his time and energy to research and development. As a result, his patented products and systems are being installed by dealers throughout the world in thousands of homes. Thanks to James' "hands-on" approach, insisting on complete follow through on each project, quality installations and service, homeowners are assured their basement waterproofing project will be done with professionalism.

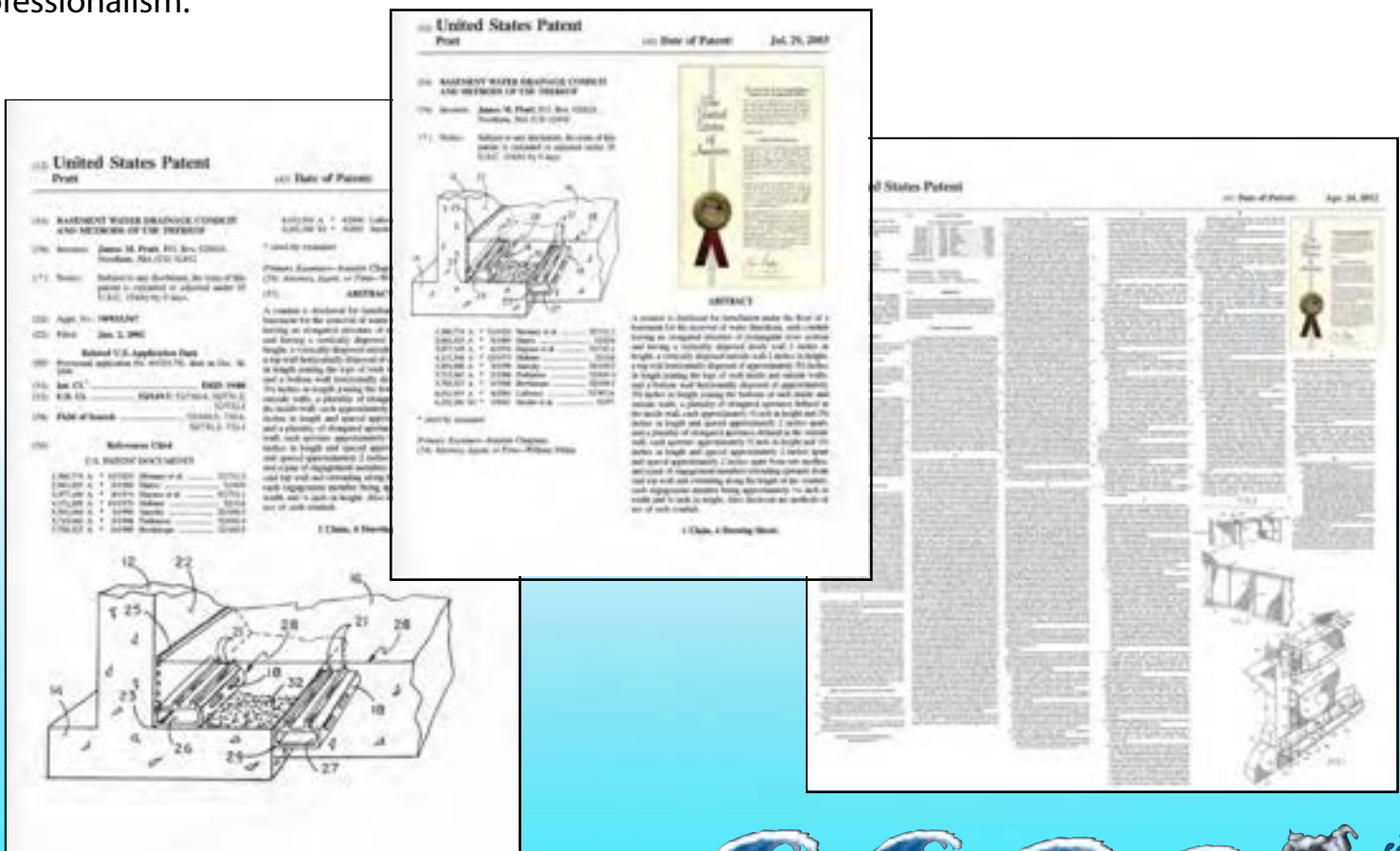



The Crawlspace Solution

Dirt crawlspaces are common in many homes and present unique problems for the homeowner. Dirt inside the home transmits humidity, odors and radon gas, providing rodents and insects an easy path into the upper living portions of the home. The humidity and dampness that is inherent in crawlspaces can also cause structural damage to the wood framing, carpets, floors and walls. This environment is a breeding ground for mold and mildew, all of which present a real health concern.

Unfinished crawlspaces are a health hazard, unsightly and a waste of precious storage space. Basement Technologies® seals off crawlspaces by covering the floor and sealing the barrier to the wall in conjunction with the proper ventilation techniques, thus insuring your family's health and well being.



Innovative Solutions for Your Crawlspace

The homeowner might consider pouring concrete over the crawlspace floor, but in a post construction setting, this is often unrealistic and impractical.

**The cost effective solution...
Busy Dog Basement Technologies'**

Crawlspace Conduit®

Home airflow mechanics, called the "whole house effect", is the natural airflow which travels towards the roof, creating a suction type effect on the crawl space dirt. This process will cause dampness and humidity to rise into the living space providing rodents and insects an easy path into the upper living portion of the home. The Crawlspace Conduit®, in conjunction with our ventilation techniques, will reduce humidity and possible mold growth throughout the home. It can also help dry up structural wood and framing. Basement Technologies® has designed a solution to the dirt crawlspace problem. The Crawlspace Conduit® will also reduce heating and cooling costs. Our Crawlspace Conduit® is similar to a concrete floor replacement when concrete is unrealistic in a post construction setting. Please ask your Basement Technologies dealer for samples.



Our dedicated professional staff is fully trained and licensed at our National Waterproofing and Crawlspace Training Center - we do not use sub-contractors!

CRAWLSPACE CONDUIT®

Consists of virgin outer layers of white high strength polyethylene film laminated together with a black layer of molten polyethylene. Both outer layers contain UV inhibitors and thermal stabilizers to assure long outdoor life. The white layers are designed to reduce heat build up and condensation and to provide excellent dimensional stability. A layer of polyester reinforcement placed between these plies greatly enhances tear resistance and increases service life. Crawlspace Conduit®'s II heavy duty diamond reinforcement responds to tears immediately by surrounding and stopping the tear.



PROPERTIES	TEST METHOD	CRAWL SPACE CONDUIT® II
Appearance		White/White
Thickness, Nominal		20 mil or 16 mil
Weight per MSF		105 lbs.
Construction		Extrusion laminated with scrim reinforcement
*1" Tensile Strength	ASTM D751	90 lbf.
Elongation at Peak Strength	ASTM D751	25%
Elongation at Break	ASTM D751	900%
*Grab Tensile	ASTM D751	135 lbf.
Puncture Strength	ASTM D4833	39 lbf.
*Trapezoid Tear	ASTM D4533	95 lbf.
Hydrostatic Resistance	ASTM D751	150 psi
Maximum Use Temperature		180°F
Minimum Use Temperature		-70°F
Permeability		
WVTR	ASTM E96 **Method A	0.010 g/100in ² /day
Perm Rating	ASTM E96 **Method A	0.022 U.S. Perms

*Tests are an average of diagonal directions.

**All testing was performed at 73°F and 50% relative humidity.

*“Windows closed and seal all vents to the outside” is the rule!
Install “mechanical” ventilation with the “Bon Aire”.*



Crawlspace Conduit™ and Your Bon Aire™ System

A must for every crawlspace!



Installing the Bon Aire™ humidity control system will help reverse the normal air flow of the whole house effect and bring warmer conditioning air to the crawlspace. Although most of the dampness will be trapped under the vapor barrier, it will be necessary to control the dampness of the air in the crawlspace.

This process, in conjunction with keeping windows and vents closed, will create a healthier, safer environment for your home.

The Air Mop® III

For serious humidity and dampness in conjunction with the Bon Aire™ system, install the Air Mop® III, a heavy duty industrial dehumidifier, to control extensive dampness in the crawlspace and to control moisture and humidity in the air.



1-800-BUSY DOG®

Basement Technologies



The Curtain Drain™

1-800-Busy Dog
Basement
Technologies



The Basement Specialists™

Basement Waterproofing

*Our patent pending solution for
“flooding surface water” by the home.*

It is common for homes, at the base of hills or inclines, to have water pooling at the home's foundation. These pools occur during heavy rain falls when water has no where else to go but by your home. It then penetrates into the basement by seeping under the siding and plywood and over the foundation. Basement Technologies' patent-pending product, **“Curtain Drain™”**, is designed to eliminate water from entering the basement due to the exterior pooling. The **“Curtain Drain™”** will take the threatening water which collects on the surface and route it to the side of the home away from the flooded areas.

Due to the extreme unpredictability of exterior environments, we cannot warranty exterior systems.

However, we proudly proclaim as a result of already installed **“Curtain Drain™”** systems that these systems work phenomenally.



FLOODING BY THE FOUNDATION CAN OVERFLOW INTO THE BASEMENT OVER THE FOUNDATION WALL.

Our **“Curtain Drain™”** system is an economical and effective system for added peace-of-mind. In addition, we can install our Finish White™ panels to the inside basement walls which would allow water to flow behind them so that the water will be re-routed into a full perimeter system beneath the floor on the inside.

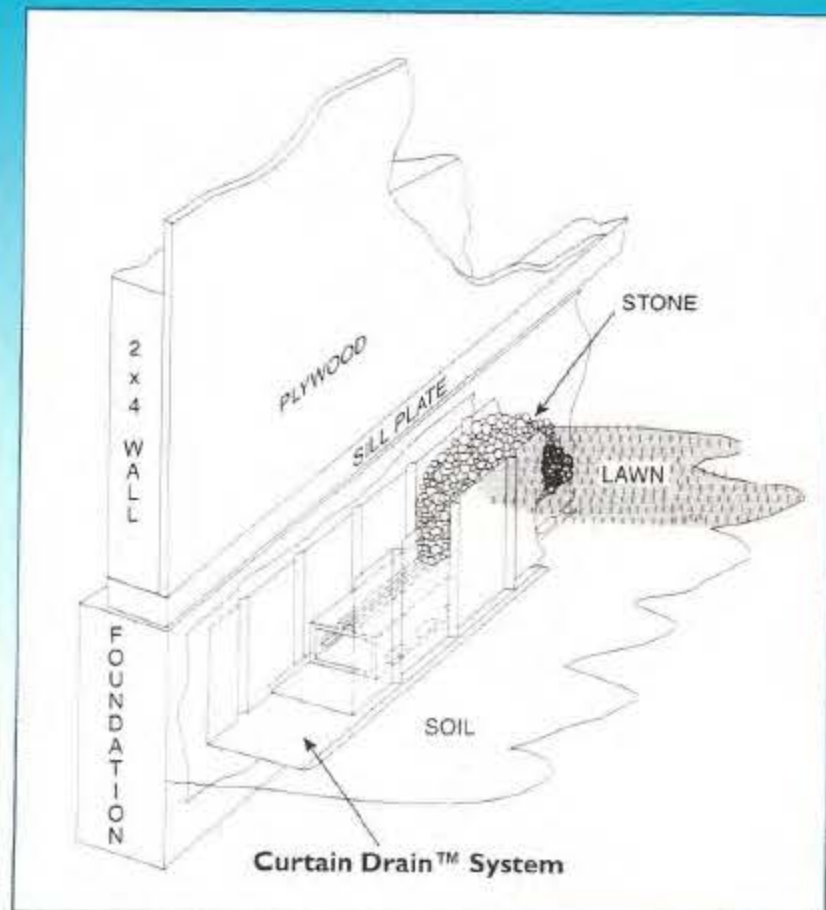

We always recommend our patented, interior system, The Water Trek Aqua Route®, be installed in conjunction with the exterior **“Curtain Drain™”**.



LAWNS LIKE THIS NEED IMMEDIATE ATTENTION.

1800BUSYDOG.COM



A 9" deep trench is dug along the base of the home for the patent pending **"Curtain Drain™"** to sit in. We install our patented Water Trek Aqua Route® conduit in the base of the **"Curtain Drain™"**. This insures no dirt or debris will clog the route of the water to the Bubbler Pot™ or the Lawn Magnum™ (see Lawn Magnum™ brochure) at the end of the **"Curtain Drain™"**. The water exits through the top of the Bubbler Pot™ onto the lawn or our Lawn Magnum™ can be installed to dispense the water underneath the lawn. These are two excellent options available to the homeowner.



1
A TRENCH IS DUG IN THE EFFECTED AREA WHERE WE INSTALL OUR DOUBLE "CURTAIN DRAIN™" PROTECTOR TO STOP DIRT FROM CLOGGING OUR WATER TREK AQUA ROUTE® CONDUIT.



2
THE WATER TREK AQUA ROUTE® IS INSTALLED IN THE PROTECTED TRENCH



6 A SPECIAL "COVER PIECE" IS INSTALLED OVER THE TRENCH PROTECTOR STOPPING WATER FROM GETTING TO THE SILL PLATE.



8
THE TRENCH IS BACKFILLED WITH DIRT ONCE THE CURTAIN DRAIN™ SYSTEM IS INSTALLED.



4
STONE IS BACKFILLED INTO THE CURTAIN DRAIN™ SYSTEM. GREY IS THE STANDARD COLOR USED, BUT WHITE OR OTHER COLORS CAN BE SUBSTITUTED UPON REQUEST.



WITH BASEMENT TECHNOLOGIES' "CURTAIN DRAIN™", WATER IS DIVERTED FROM THE HOME TO ANOTHER AREA OF YOUR LAWN.



THE LAWN MAGNUM™, DESIGNED BY BASEMENT TECHNOLOGIES AND A CANADIAN ENGINEERING FIRM, CAN DISPENSE MOST WATER UNDERNEATH THE LAWN.



WATER IS DISPENSED ONTO THE LAWN SURFACE WITH THE BUBBLER POT™.



10
FINISHED CURTAIN DRAIN™ VARIOUS COLORED STONE ARE AVAILABLE



"Dog Tank"™

Water Management System

by Basement Technologies®



The "Dog Tank"™ by Basement Technologies®, is designed to meet the most stringent company and industry standards, while providing an effective alternative for high volume sump pump drainage discharge issues. Basement Technologies® waterproofing system comes with a lifetime warranty, stating water will not get into the basement in the areas treated. Most systems require a pumping unit, and that water is usually placed in the yard. There are few water management drywell systems that are infallible, but this system is most likely to be successful in certain applications.

Placed underground, Basement Technologies® Dog Tank™ will hold approximate 31 ft³ or 224 gallons of water, plus there are 6 inches of stone underneath the Dog Tank™ with approximately a yard of stone on the sides and, if the surrounding soil porosity allows the water to drain into the area around the Dog Tank™, there's less of a chance of the water getting onto the surface.

Multiple Dog Tanks can be set up and tied together under the ground for larger water capacity issues and needs.

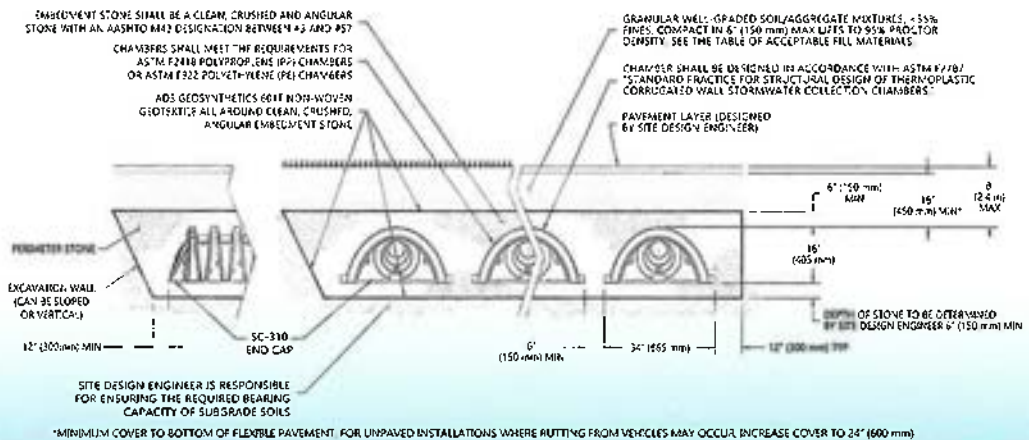
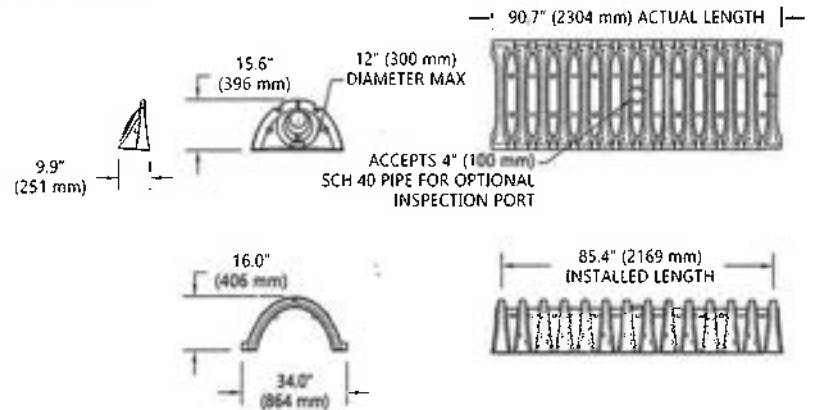

STORMTECH CHAMBER NOMINAL SPECIFICATIONS (NOT TO SCALE)

Size (L x W x H)
85.4" x 34.0" x 16.0"
2,170 mm x 864 mm x 406 mm

Chamber Storage
14.7 ft³ (0.42 m³)

Min. Installed Storage*
31.0 ft³ (0.88 m³)

Weight
37.0 lbs (16.8 kg)

1-800-BUSY DOG®

"Where design and innovation keys our superior products™"





Although there are many causes for foundation problems, Lifting your home back to being level is not as hard as you may think. Basement Technologies[®] utilizes the best post-construction lifting/piering system on the market today developed by DynaPier[®]. We get under your footing and lift the house up.

Piering systems work on a basic mechanic:

Drill + Lift + Hold.

Unlike other companies that tie onto the footing from the side with brackets and proceed to lift the footing and structure sideways, Basement Technologies[®] lifts your home from under the footing. Lifting the footing, which in turn, lifts the house and holds it permanently is the best way to ensure a stable foundation.

Causes of Foundation Problems

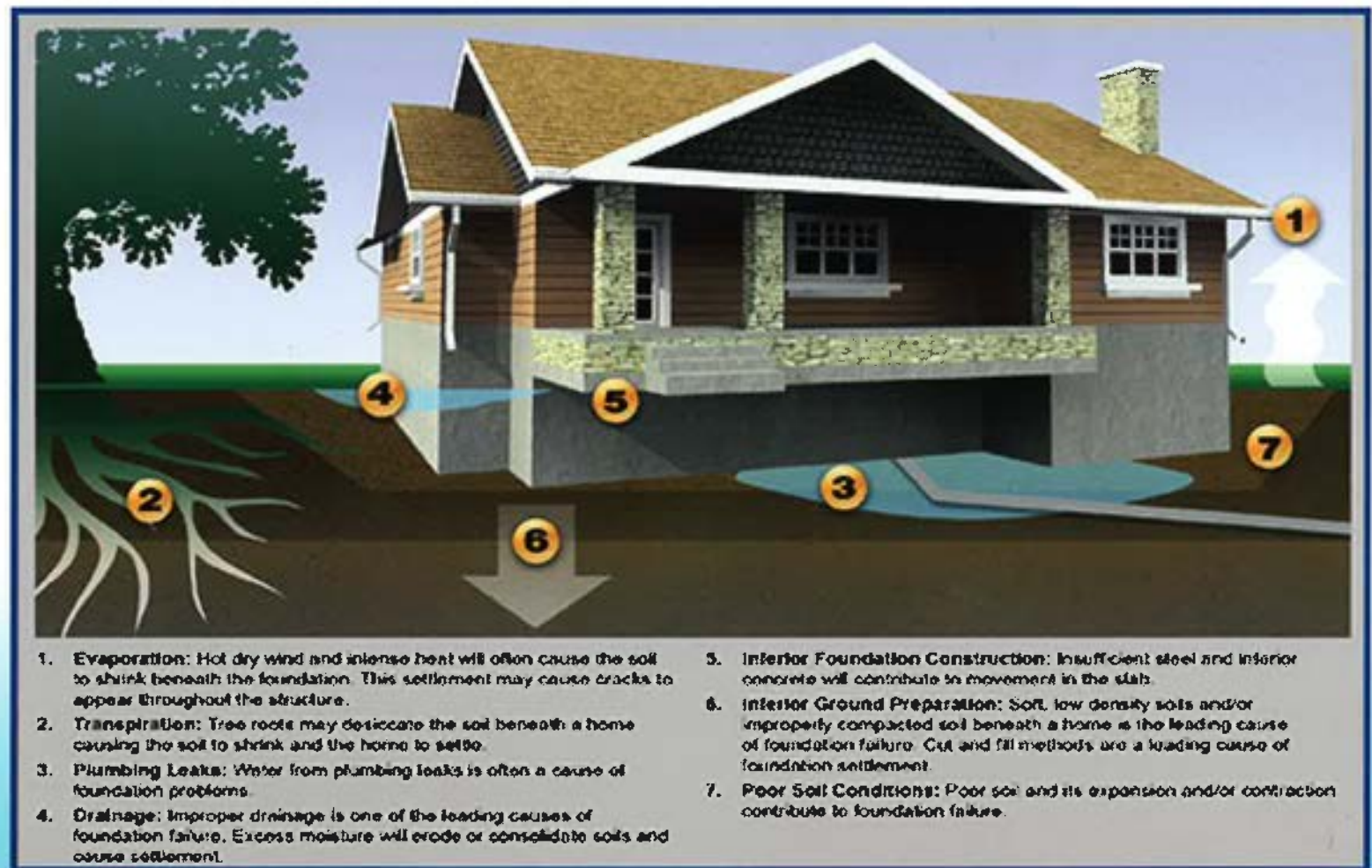

Why DynaPier® Is The Best

Basement Technologies
The Basement Specialists™
Structural/Remodeling Division

The DynaPier® system was designed to be the strongest foundation pier in the industry by combining steel and high strength concrete. It is installed centrally beneath the footing rather than outside of the footing, thus transferring the structural load directly on top of the foundation pier. The DynaPier® will achieve the greatest depth while installed in a position to provide the greatest support. No other piercing system can make these claims.

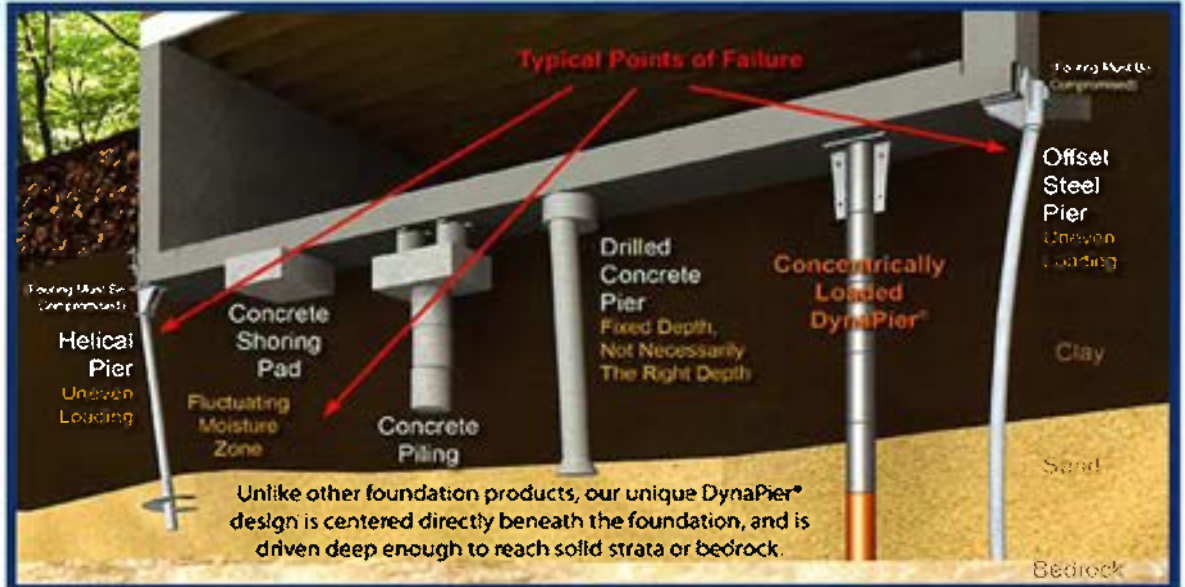

Technical Specifications:
DynaPier® segments are comprised of 2-7/8 diameter 5 gauge powder-coated or galvanized tubing. The steel segments are pre-cast with 8,800 psi concrete mix. Segments that have cured for 28 days can withstand compressive loads in excess of 75 tons.

- The pier is located centrally and directly beneath the foundation footing.
- All parts are connected to form a monolithic unit.
- Installation does not require removal or breaking of the footing; footing remains completely intact.
- ALL shims are contained within the pier cap.

The result is a foundation that far exceeds the home's original structural integrity, making your foundation better than new.

What The Experts Say!

Willard Norton, a founding partner of Norton & Schmidt, a respected engineering and consulting firm states that "Because its design incorporates concentric loading of the pier during installation and support of the foundation, and is filled with a concrete mix that tests in excess of 3500 psi, it has the capacity to punch through rock floaters to solid bearing without being turned away from the vertical position."

And Don Carter, an experienced and highly-respected consulting engineer specializing in foundation design and performance, states "It is my professional opinion that the DynaPier system has proven capacity to meet foundation repair duty for which it is being marketed, with a safety factor of 2."

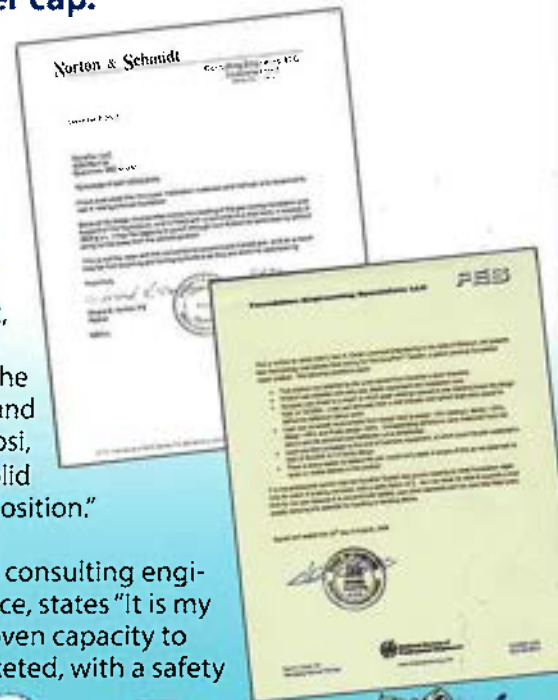

1-800-Busy-Dog

www.basementtechnologies.com



DynaPier®



Go Deep With DynaPier!

DynaPier®

Go Deep With DynaPier!

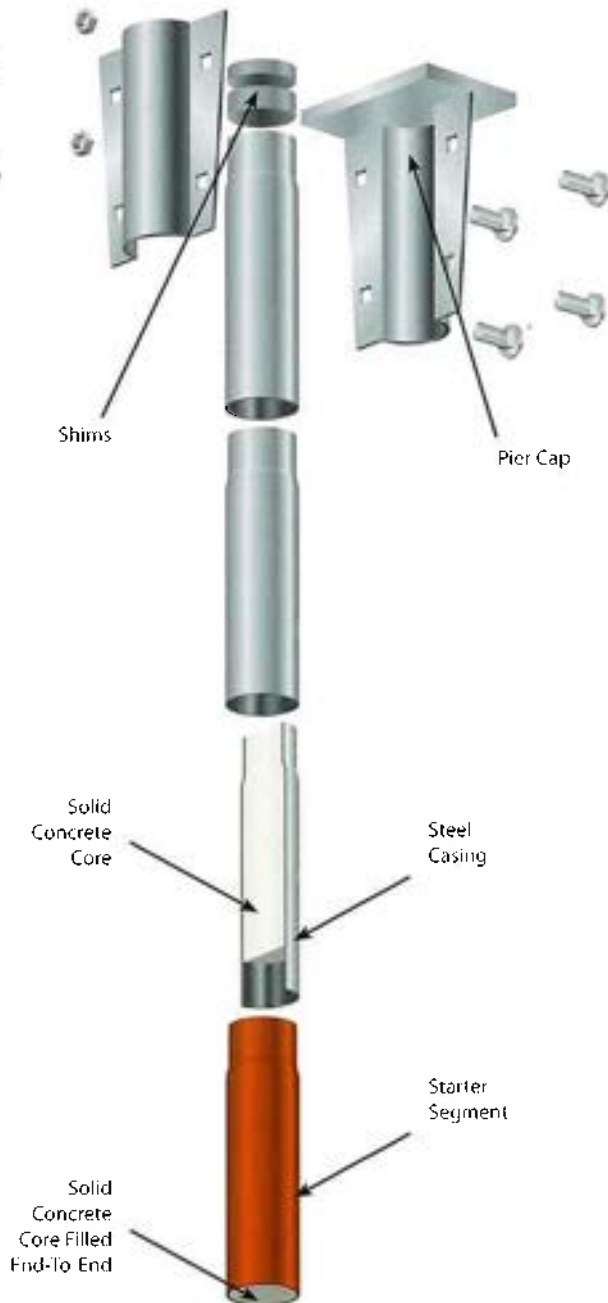

Technical Specifications:

DynaPier® segments are comprised of 2⁷/₈" diameter 8 gauge powder-coated tubing. The steel segments are pre-cast with an 9,000 psi concrete mix. Segments that have cured for 28 days can withstand compressive loads in excess of 75 tons.

The Unique DynaPier® System



The DynaPier® system was designed to be the strongest foundation pier in the industry by combining steel and high strength concrete. It is installed centrally beneath the footing rather than outside of the footing, thus transferring the structural load directly on top of the pier. The DynaPier® will achieve the greatest depth while installed in a position to provide the greatest support. **No other piercing system can make these claims.**

The patented DynaPier® is comprised of high-strength concrete that is pre-cast in a steel sleeve which provides superior shear strength and compressive resistance as proven by independent testing labs. The outer steel casing is filled with a concrete core, and cured for maximum strength. The DynaPier® segments are hydraulically driven into the ground one at a time. After one DynaPier® segment is driven, another segment is connected to the pier, and the process is repeated until the foundation pier hits bedrock or a dense strata of subsurface material. A temporary platform is attached to the pier so that the structure can be lifted. Once the desired lift is achieved the pier is extended up to the footing and the pier cap is attached to the pier.

- **The pier is located centrally and directly beneath the foundation footing.**
- **ALL parts are connected to form a monolithic pier.**
- **ALL shims are contained within the pier cap.**
- **Installation does not require removal or breaking of the footing; footing remains completely intact.**

The result is a foundation that far exceeds the home's original structural integrity, making your foundation better than new.

Causes Of Foundation Problems

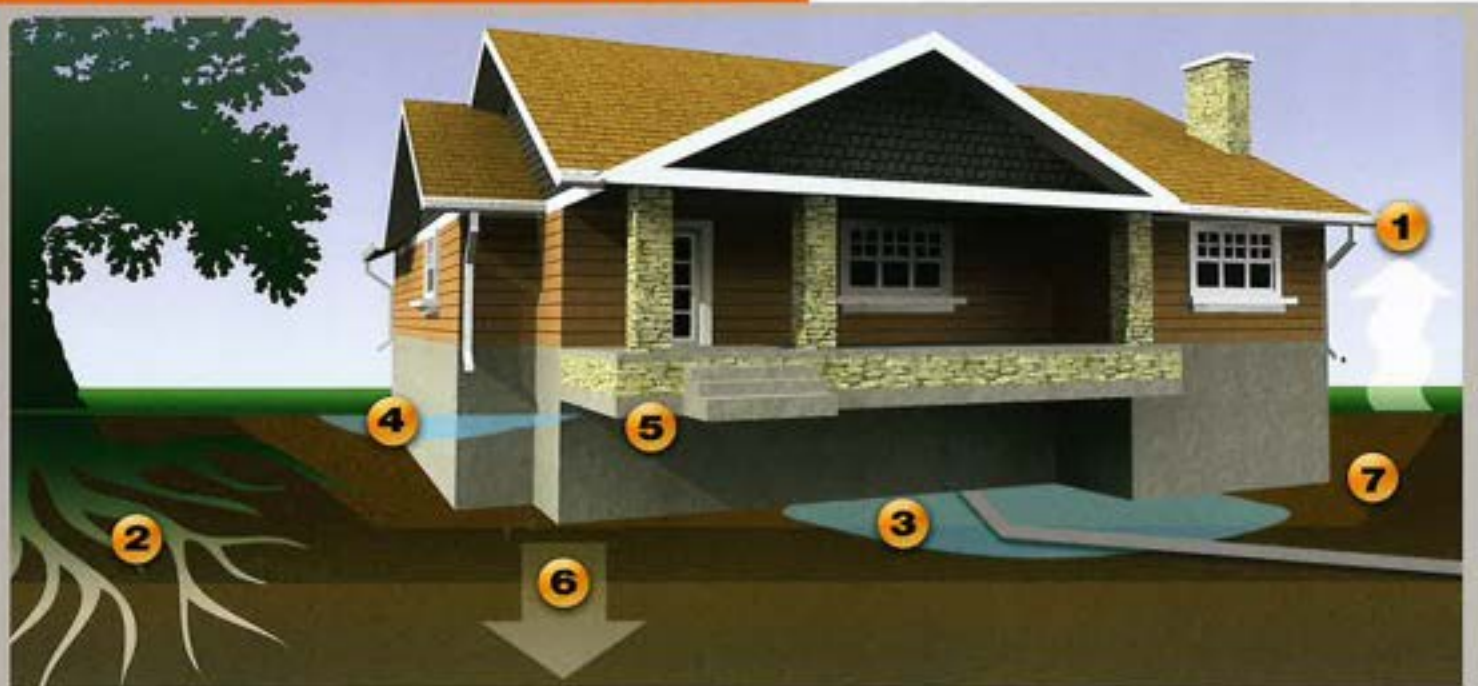

- 1. Evaporation:** Hot dry wind and intense heat will often cause the soil to shrink beneath the foundation. This settlement may cause cracks to appear throughout the structure.
- 2. Transpiration:** Tree roots may desiccate the soil beneath a home causing the soil to shrink and the home to settle.
- 3. Plumbing Leaks:** Water from plumbing leaks is often a cause of foundation problems.
- 4. Drainage:** Improper drainage is one of the leading causes of foundation failure. Excess moisture will erode or consolidate soils and cause settlement.
- 5. Inferior Foundation Construction:** Insufficient steel and inferior concrete will contribute to movement in the slab.
- 6. Inferior Ground Preparation:** Soft, low density soils and/or improperly compacted soil beneath a home is the leading cause of foundation failure. Cut and fill methods are a leading cause of foundation settlement.
- 7. Poor Soil Conditions:** Poor soil and its expansion and/or contraction contribute to foundation failure.

Why DynaPier® Is Best

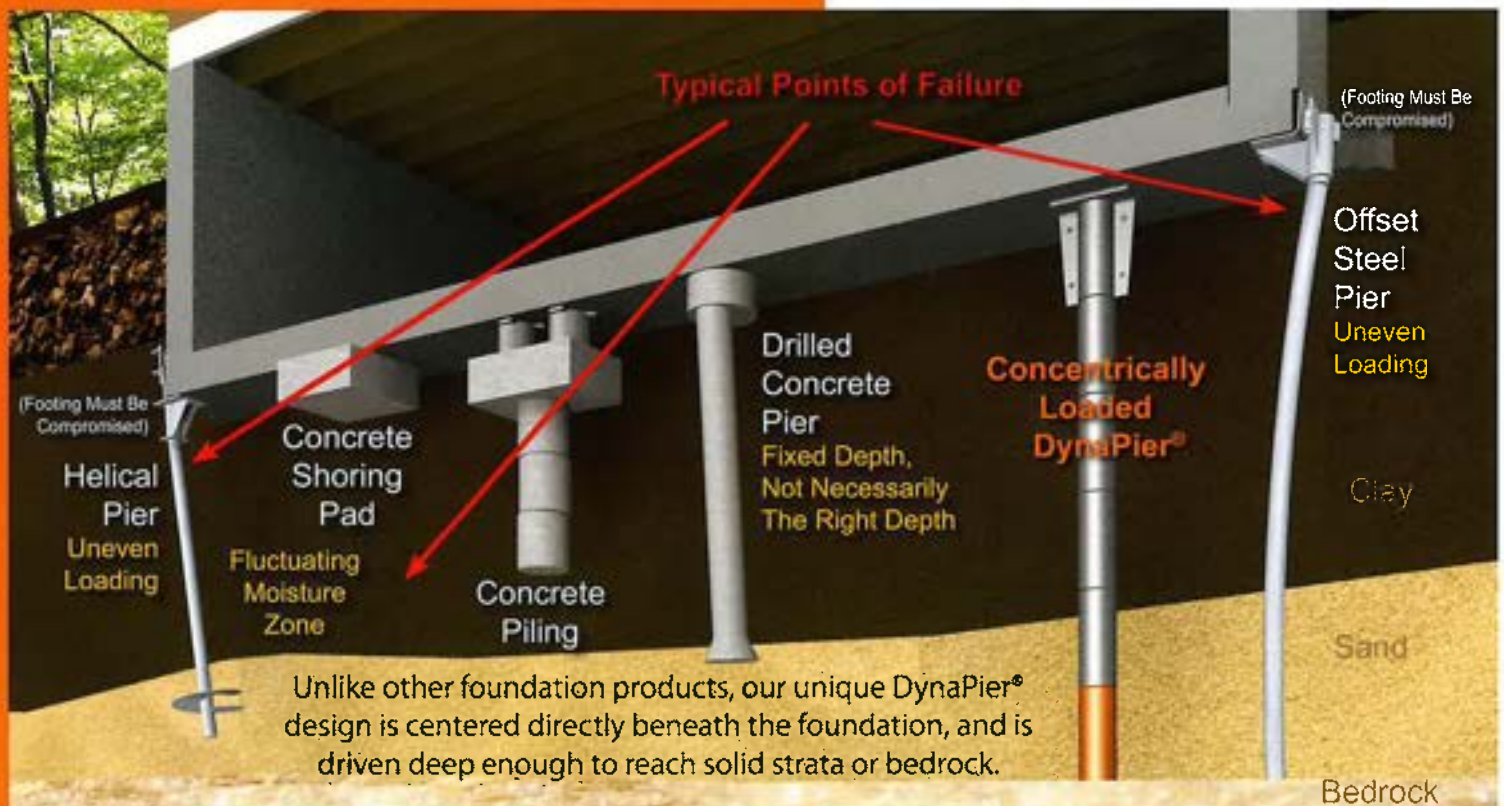

What Experts Say About The DynaPier®

Willard Norton is a founding partner of Norton & Schmidt, a respected engineering and consulting firm that provides design and inspection services for new construction, existing building renovation and restoration, parking garage restoration, general consulting, residential consulting and expert testimony.

Norton & Schmidt

Consulting Engineers, LLC
Established 1967
Kansas City - Atlanta

December 7, 2007

DynaPier, LLC
4220 Main St
Grandview, MO 64030

TO WHOM IT MAY CONCERN:

I have evaluated this firm's pier installation materials and method, and observed its use in raising a house foundation.

Because its design incorporates concentric loading of the pier during installation and support of the foundation, and is filled with a concrete mix that tests in excess of 3500 p.s.i., it has the capacity to punch through rock floaters to solid bearing without being turned away from the vertical position.

This is not the case with the conventional eccentrically loaded pier, and as a result they fail from buckling and turning by floaters as they are driven to solid bearing.

Yours truly,

Willard S. Norton

Willard S. Norton, P.E.
Partner

WSN/rj

311 E 11th Avenue • North Kansas City, MO 64116 • (816)

DynaPier®

DynaPier, LLC
13902 Norby Rd
Grandview, MO 64030
toll free: 844-456-3962

Foundation Engineering Specialists LLC

FES

This is written to certify that I, Don R. Carter a licensed engineering in the state of Missouri, did prepare test methodology and witness field testing for The DynaPier™ System, a patent pending foundation repair product. The following conditions apply:

- Test product was selected by the undersigned from DynaPier's stock inventory.
- Product was installed with daily-use, dealer equipment and installation crew.
- DynaPier was driven to a depth at which gage readings showed it was resisting twice the design load, or 33,600#. Load was removed, then a dial indicator and optical level were placed to define the deflection datum point.
- Load was increased incrementally from design load to design +5% (takeup), design +24%, design +49% and finally design +64%. Corresponding deflections were measured from the datum and the attached load deflection curve established.
- Load was then increased to the limit of hydraulic equipment, at which point the pier sustained a load of 40,255# or 2.4 times design.
- There is every reason to believe the pier would carry loads in excess of this as we observed no strain or visible distress in the product.

It is my professional opinion that the DynaPier System has proven capacity to meet foundation repair duty for which it is being marketed, with a safety factor of 2. We may never be able to quantify a load limit for this pier because it is concentrically loaded, uses short segments and has concrete filled tubes, greatly reducing the potential for buckling or bending failure.

Signed and sealed this 16th day of August, 2008



Don R. Carter PE
Managing General Partner

National Society of
Professional Engineers
www.fdrengineering.com

913-685-1434
913-709-8633

Don Carter is an experienced and highly respected consulting engineer specializing in foundation design and performance. After testing the DynaPier® System, Don Carter said,

"We may never be able to quantify a load limit for this pier because it is concentrically loaded, uses short segments, and has concrete filled tubes, greatly reducing the potential for buckling or bending failure."

ELITE CRETE™ THIN FINISH CONCRETE FLOOR & WALL OVERLAYS

Basement Technologies
The Basement Specialists™
Structural/Remodeling Division

Interior/Exterior Floor & Wall "Thin Finish"

Finish your floor with a design color of your choice. This unique advanced floor and wall system is unique utilizing your choice of colors and designs. This system can be used on any concrete surface.

- Walls or floors
- Economical
- Fast
- Designer Finishes
- Goes right over existing concrete



Why
remove old
slabs to get
a designer
finish?

**Thin Finish: we offer
9 designs to choose from**

Upper End Thin Finish
(hand finish and trowel done)



Economical Finishes



1-800-BUSY DOG®



POOL DECK, DRIVEWAY AND PATIO COATINGS

Pool Deck Coatings are polymer modified to act as surface repair or an aesthetic finish that can be applied to new or existing concrete surfaces. The coating is actually stronger than concrete and can withstand vehicular traffic and harsh temperatures (extreme hot or cold).

- Virtually unlimited designs, patterns, textures and color options
- Non-slip, even when wet
- Can create the authentic look and feel of any stone, brick, tile, wood and even just plain new concrete
- Available in any color combination to match surrounding design
- Cost effective compared to: full depth stamped concrete, pavers brick, real stone or integrally colored concrete
- Extreme durability for high traffic areas
- Very low maintenance
- Highly resistant to deicing salts, freeze/thaw climates, extreme heat wet conditions and UV rays
- Quick installation time
- Can be installed pre- or post-construction
- For new or existing concrete surfaces



Digital catalog of finishes available.
See elitecrete.com

1-800-BUSY DOG®



THE FIELDSTONE WALL CONDUIT®

THE MOST INNOVATIVE SOLUTION FOR YOUR
FIELDSTONE WALLS

Homeowners may consider tearing out their fieldstone walls and replacing them with more conventional walls due to frustrations associated with water, mold, dirt, odors, pests and rodents. In older homes, it was common to dig out the basement and install stone walls. Older homes offer old world charm and craftsmanship along with a high market evaluation. A fieldstone wall basement is usually unsightly, wet, damp and moldy. It makes little economic sense to redo the foundation. Fieldstone walls have joints and cracks where the mortar (concrete) was installed to join the stones. Water, air, rodents and insects can get in through these cracks. 1-800-Busy Dog Basement Technologies® Fieldstone Wall Conduit® solves the problem permanently and cost effectively. Our solution seals all the problems out and effectively creates a new

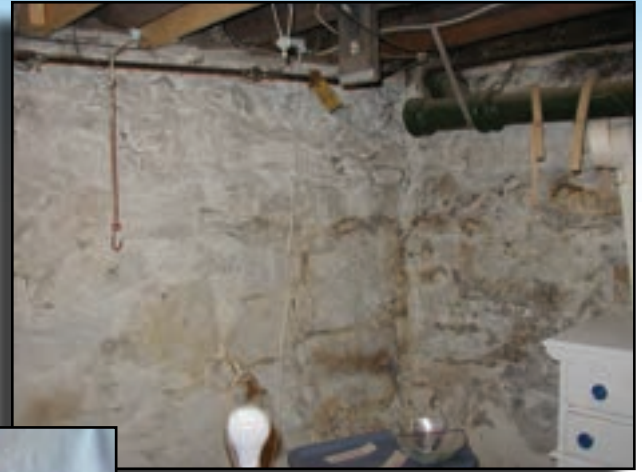

Before

living space, free of insects, dirt, rodents and water. The Fieldstone Wall Conduit® is ideally used in conjunction with a full perimeter Water Trek Aqua Route® system.



After

The Most Cost Effective Solution...



Finish White®

Basement Waterproofing Wall Panels

Authorized Dealer
Basement Technologies
The Basement Specialists™
Basement Waterproofing

Finish and waterproof your basement walls in one step.

The Finish White® panel system transforms your unfinished basement into a finished room and waterproofs the walls at the same time. The huge expense of complete remodeling is now eliminated. You can add a significant amount of living area to your home for a fraction of the cost.

Basement Technologies® Finish White® is the perfect finishing touch to your newly dry basement. It keeps your basement walls dry and looking beautiful. Washable, attractive, permanent and very cost effective – Finish White® is the economical choice for your basement walls.

Basement Technologies® Finish White® attaches directly to your poured or brick foundation walls and is best used in conjunction with a full perimeter Water Trek Aqua Route® system.



BEFORE



AFTER

Cut finishing costs and waterproof at the same time!



Finish White® Panels attach directly to your basement walls.

Custom Tailored Waterproofing.®

Improving Basement Waterproofing From The Ground Up™





Permanent Basement Wall Repair

Best under pressure.

THE ONLY SOLUTION WITH
ALL THESE BENEFITS:

- ICC-ES building code certification.
- Lifetime warranty.
- Stronger than original wall.
- Carbon fiber & Kevlar system.



The Fortress Stabilization System is protected by Patent No. 7743585, 7823354, 8142102, 8367569, 9034775, 6746741, 6846537, RE39839, 9528286, 9290956, 9290957, 9790697, 3040496 and other pending patents.

A Complete System For A Complete Solution

Top Anchor

The first company to develop a top-of-wall anchor.

The Fortress top anchor is post-tensioned after installation. This ensures that the top anchor and wall are engaged under tension, and holding fast, when the job is complete. No other company has a post-tensioned wall anchor.

Bolting to the rim joist is safer. The sill plate is not adequately connected to the floor joist to carry the load. The Fortress top anchor is mechanically fastened to the rim joist, not the sill plate. By connecting to the rim joist, the Fortress top anchor engages the building's floor system, providing a stronger, more durable anchor. This prevents any movement of the basement wall.

A stronger connection. Many older homes do not have enough sill plate-to-foundation wall connections to ensure that the sill plate will hold under stress. Engaging the floor system (first story floor to top of basement wall) provides the strongest, safest connection.

Bottom Anchor

The best in the industry. Here's why:

The quality of the bottom anchor construction is very important. Because preventing shear requires strength, we made our bottom anchor over 5 times thicker and 125 times stiffer than the competition. In addition, we make sure that the connection to the foundation is absolutely secure. We use a dual leg solution with specific contact lengths engineered to achieve a 200% safety factor. Our bottom plate anchor is the best in the industry.

The Fortress bottom anchor secures your wall from shear slide. Shear slides can occur at the bottom of masonry walls where shear forces are greatest. This inward movement of the wall is defined as shear. In typical situations the basement floor holds the bottom of your wall from moving in, but where there are excessive shear forces, the Fortress bottom anchor is needed. The bottom anchor uses the basement floor to secure the Carbon-Kevlar strap and prevents shear slides. The bottom anchor is used in both block and poured concrete walls.

The best solution to bottom-of-wall anchors. The Fortress bottom anchor takes the proven American Concrete Institute recommendation for anchoring carbon fiber straps and makes it better.



What goes into the Fortress Carbon-Kevlar Strap?

Not all carbon fiber is created equal.

Before considering another carbon fiber system, ask how their fibers are arranged. Conventional manufacturers commonly weave the carbon. This produces an attractive woven pattern, but this method also crimps the fibers while going over and under each other. When force is applied to a woven pattern, the bent fibers try to straighten out, which reduces effectiveness.

You can see that it's done right.

Fortress has always been concerned with having the best composite performance. All strength in fiber composites is gained when the fibers are straight. Unidirectional fibers lay flat, eliminating flex when force is applied. The unidirectional method Fortress has developed creates a product twice as strong as products using woven carbon fibers. This Fortress proprietary manufacturing process allows for a true unidirectional carbon product, which is the perfect tool to reinforce foundations.

Exclusive open grid technology.

The Fortress open grid technology (OGT) combined with epoxy rivet technology (ERT) connects to the carbon grid to form a mechanical bond to the wall. Epoxy rivet technology forms an adhesive bond between the grid and the masonry substrate which lead to the carbon fiber, creating an adhesive bond as well as a mechanical "rivet" between each fiber of the grid. There are over 8,000 epoxy rivets securing a single strap to your wall. OGT and ERT are exclusive to the Fortress system.



Strongest strap available. Fortress is the strongest carbon fiber system available. Every lot produced is tested to meet our guaranteed minimum tensile strength of 234,700 psi. For full details, view the Fortress Carbon Grid Strap Design Manual on our website.

Product	Ultimate Tensile Strength (psi)
Fortress Carbon-Kevlar	234,700
Zoltek Panex PX35	203,000
VSL V-Wrap C100	140,000
Edge FiberBond	140,000
Quakewrap TU27C	135,000
Fife Tyfo SCH-41	121,000
Sika SikaWrap Hex 117C	105,000
Competitor R	51,571

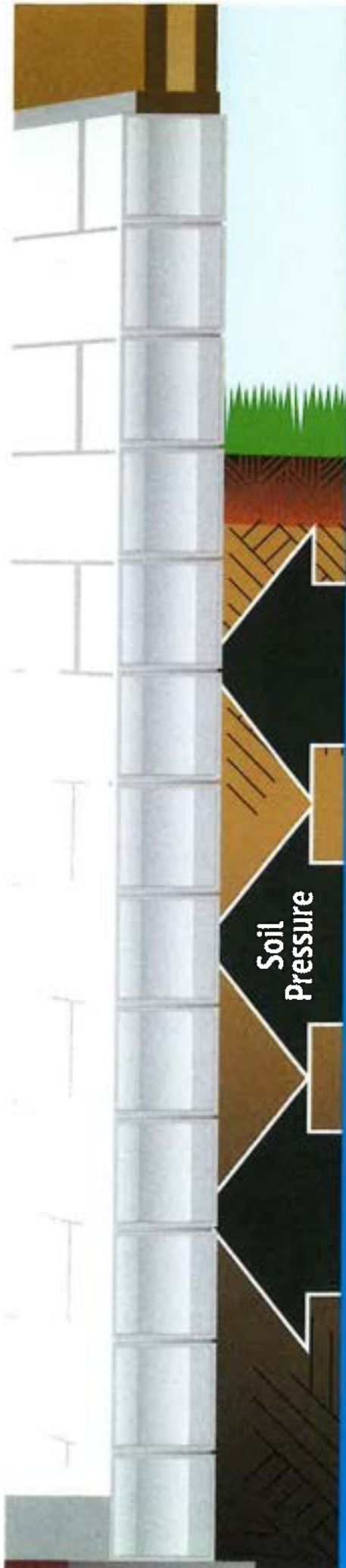

The Only System With ICC Certification and a Lifetime Warranty



What does "ICC certified" mean?

The International Code Council (ICC) was formed in the 1990s by the three major U.S. regional building code agencies and developed the current International Building Code. This code is used to protect public health and building safety throughout the United States and in countries around the world. ICC developed its Evaluation Service (ICC-ES) to certify that products intended to be installed in a home or business are safe and are building code approved. Certification by the ICC-ES means a product and its manufacturing process have been tested, evaluated and regularly audited by ICC to meet or exceed product performance reliability. Fortress obtained ICC-ES certification through a rigorous testing process performed by an ISO 17025 accredited laboratory at the University of Miami, Structures and Materials Laboratory. The ICC-ES certification identifies Fortress Stabilization Systems as a premier building product manufacturer able to produce consistent and reliable product performance. A copy of the Fortress Stabilization Systems' ICC-ES report is located on our web site.

Why does ICC certification matter?

An ICC-ES approved product can be immediately identified by any code official, home inspector, or bank appraiser as building code approved. The ICC ESR report number identifies the Fortress system as approved by every local building code agency in the United States. This means a Fortress certified product will pass every building code inspection so you can have peace of mind that it's safe for your home. Fortress' transferable lifetime warranty together with ICC-ES certification will show potential buyers and lending institutions that you installed the best system available if you ever decide to sell your home. Trying to sell your home without a building code approved system could be a very costly mistake. Make sure you use only an ICC-ES, building code approved product.

Proudly made in the USA. The Fortress top anchor, bottom anchor and Carbon-Kevlar straps are made in the USA at our 25,000-sq.ft. manufacturing facility in Holland, Michigan.



184 West 64th Street, Holland, MI 49423
Tel: 616-355-1421 Fax: 616-355-1428
Email: Solutions@FortressStabilization.com

1-800-207-6204 | FortressStabilization.com



FREEZE STOP™

Patented Discharge Line Protector

**1-800-Busy Dog
Basement
Technologies**
The Basement Specialists™
Basement Waterproofing



The discharge for the sump pump is always an area of concern. Many pump failures and flooded basements are a direct result of frozen discharge lines, especially in colder climates.

The patented Freeze Stop™, with a full 360° of protection, is discreetly installed on the outside of your home and is engineered to facilitate the flow of water from the inside of your home to the buried pipe outside.

Most waterproofing systems operate with sump pumps. The sump pump usually discharges to the outside of the home. Exterior discharge lines can easily freeze when it gets cold. The pump will continue to run, but due to the frozen discharge line, water could back up and cause your basement to flood.



Not Any More! Our patented Freeze Stop™ eliminates this from ever happening. We guarantee, our Water Grabber® sump pump will never back up due to exterior freezing again. Ask your representative about our unique Water Grabber®, Bubbler Pot™, Freeze Stop™ (patented), Alternator™ (patented) and Water Trek Aqua Route® (patented) combination. It works... **we guarantee it!**

Only 1-800-Busy Dog Basement Technologies® Freeze Stop™ with its unique patented design, features a full 360° of protection from freezing.

Dripping water from the gutters or eave line can also accumulate on the outside structure, causing ice build-up, restricting the flow of water. The added protection of the 360°

“Rest Easy” it’s patented for a reason... it works better – *guaranteed!*



designed Freeze Stop™ makes it virtually impossible to fail. 1-800-Busy Dog Basement Technologies installs only the finest patented products and warranties your basement will be dry forever! Your BUSYDOG® dealer always recommends installing the patented Freeze Stop™ with each Water Grabber® installation and, in conjunction with a full perimeter Water Trek Aqua Route® system.

Weather conditions like this make the Freeze Stop™ and Alternator™ combination an invaluable part of your basement waterproofing system.

www.1800busydog.com



Hot Floor™

Insulated Flooring System

Authorized Dealer
Basement Technologies
The Basement Specialists™
Basement Waterproofing

Makes your basement feel like part of your upper home ...
cozy and comfortable.

The Hot Floor™ is a specially insulated, padded barrier installed on top of your concrete basement floor, under the plywood and flooring. It is unique in that it actually gives you the warmth and comfortable feeling of a "hot floor", similar to the top floor of your home.

Headroom height loss is kept to 3/4" to 1", as opposed to the more costly "sleeper" systems (2x4's, plywood and insulation) causing as much as 3" to 5" loss of headroom.

Finish your largest usable area with Basement Technologies® Hot Floor™ insulated flooring system. Make your basement feel like a 2nd floor! A true cost effective improvement to remodeling your basement. Basement Technologies® Hot Floor™ is best used in conjunction with a full perimeter Water Trek Aqua Route® system.



The Hot Floor™ adds an insulated pocket under the floor keeping condensation and dampness out of your carpet. It is the perfect complement to your newly dry basement and new living or storage space.

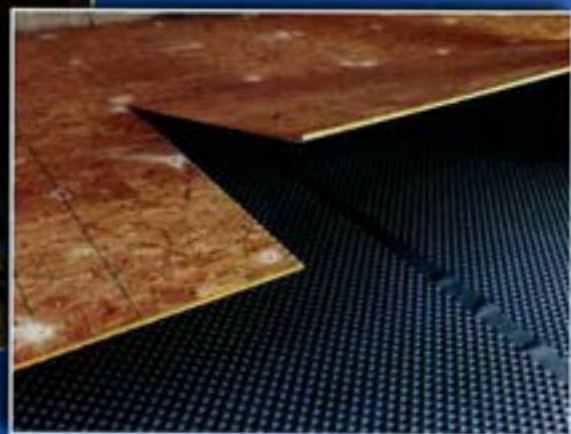

Custom Tailored Waterproofing.®

Improving Basement Waterproofing From The Ground Up™



HUMID-EVAC®

THE HUMIDITY EVACUATION SYSTEM

**1-800-Busy Dog
Basement
Technologies**
The Basement Specialists®
Basement Waterproofing

Basement Technologies recognizes that to be the leader in the basement waterproofing industry we must design and introduce new products to address old and new problems. Basement Technologies' Research and Development department has utilized a revolutionary concept in basement waterproofing technology and proudly introduces the Humid-Evac® to our customers.

EVACUATE THE DAMP AIR BEFORE IT GETS IN

Our revolutionary new product – Humid-Evac® – deals with humidity and condensation issues by drying under the slab before the moisture enters the basement. Independent research (see A) shows that 80% of moisture (condensation) in the basement originates from under the slab.

Our system is not a radon system.



BASEMENTS ARE SIMILAR TO A CAVE

Basements are below ground level and are conducive to a damp, wet environment. Independent studies (see A) show that up to 80% of moisture in a basement originates from under the floor, and if the source of the dampness is addressed, 80% of the problem is eliminated.

Radon professionals throughout the world have been unknowingly drying slabs and basements while curing the radon problem using sub-slab depressurization systems. Drafting the air under the slab dehumidifies your basement in a far superior manner than any current method on the market (see A on next page). After years of research and development, Humid-Evac® is designed exclusively to dry the basement floor and environment.

THE SUBFLOOR DRAINAGE SYSTEM IS ALWAYS THE FIRST STEP

The flooding of the basement must be stopped before any humidity or condensation problem can be addressed. We

always recommend a full perimeter Water Trek Aqua Route® system be installed prior to dealing with condensation and humidity.

WHAT IS COMMUNICATION UNDER THE FLOOR?

The science of communication under the floor is the ability to reach the entire subfloor area with a negative air pressure field. However, communication is based on sub-surface soil porosity and density of subfloor soil. For example, if there is gravel present, there will be good communication. If there is dense clay, there will be less communication. The Water Trek Aqua Route® system merely guarantees necessary communication under the slab, as well as, stopping the "flood waters".

Psychometry- the engineering science of drying a structure. In order to achieve a psychometric solution, four things need to be addressed:

1. Air Drying - removing damp air
2. Moisture on Surfaces
3. Air Movement - sub-slab and above slab
4. Temperature of the Air - take the cool damp air from the sub-slab and heat it by replacing with warmer air

The Humid-Evac® system addresses "all of the above" and cures most, if not all, dampness problems.

**THE HUMID-EVAC® IS NOT A
RADON MITIGATION SYSTEM**

www.1800busydog.com®



Independent Research Proves that 80% of Moisture Within the Building Originates from the Sub-Slab Area!

Other systems work but do not address the source of the problem; most of the source of the moisture is under the floor (see A). There are several ways to eliminate moisture:

1. **DEHUMIDIFIER:** This method allows dampness to return not really solving the "source issue". These dry the air only.

2. **AIR EXCHANGE SYSTEMS** (Bon Aire, Humidex, Humivent): This method takes warm, dry air from the upstairs to the basement area. An excellent process, but the problem still remains if it is humid in the upper portions of the home, or the customer does not use air conditioning in the home. The air exchange can be ineffective if we draw humid air from upstairs possibly nullifying any benefit the air exchange makes. This method is cost effective, but sometimes dehumidifiers may be a mandatory supplement depending on humidity levels in the home. This is a good method to eliminate odors in the basement.

3. **HUMID-EVAC®:** The "Source Solution". Evacuates cold, damp air from under the slab and helps dry the floor and a humid, damp basement. Our system works best with a full perimeter, subfloor Water Trek Aqua Route® system and Water Grabber® Bull Dog™ installed. The system consists of one (1) Water Grabber® Bull Dog™ liner with pipe attached to the Humid-Evac® fan through the side of the home. The fan costs approximately \$17.50 per year to operate, an energy savings of 60% per year over dehumidifiers. The fan runs continuously, but uses very little energy to accomplish the negative pressure field. By reducing the entrapped moisture, a dryer basement is created which reduces mold and eliminates odors.

It is natural for a basement to be damp. Sometimes we must create an "unnatural act" to thoroughly dry it. Some of the biggest complaints homeowners have are damp floors and humid basements. Even though water is stopped by our Water Trek Aqua Route® system, dampness can still occur due to temperature difference between the subfloor and basement air, and basic humidity levels of the air. The condensation should cease due to the temperature equilibrium and moisture extraction.

HUMID-EVAC®:

• Installed using our Water Grabber® Bull Dog™ liner as a large collection point for the subfloor air, the liner is sealed and draws air from the sub-slab. We always recommend a full perimeter Water Trek Aqua Route® system to enhance communication under the slab.

• Ventilation can be further enhanced by a small hole in our piping system called the Above Grade Evacuator or AGE. When the AGE is installed, vents to the upstairs through the floor or doors are necessary. This allows for further air exchange in the basement.



Active subfloor humidity evacuation units have been in use for years. Numerous independent studies have been conducted and the facts state this method is superior to many others and is economical. Basement Technologies has taken this a step further and has made a system unique to the industry ... effectuating state-of-the-art dehumidification. Basement Technologies now offers a cost effective solution to those homeowners in need of such a service.

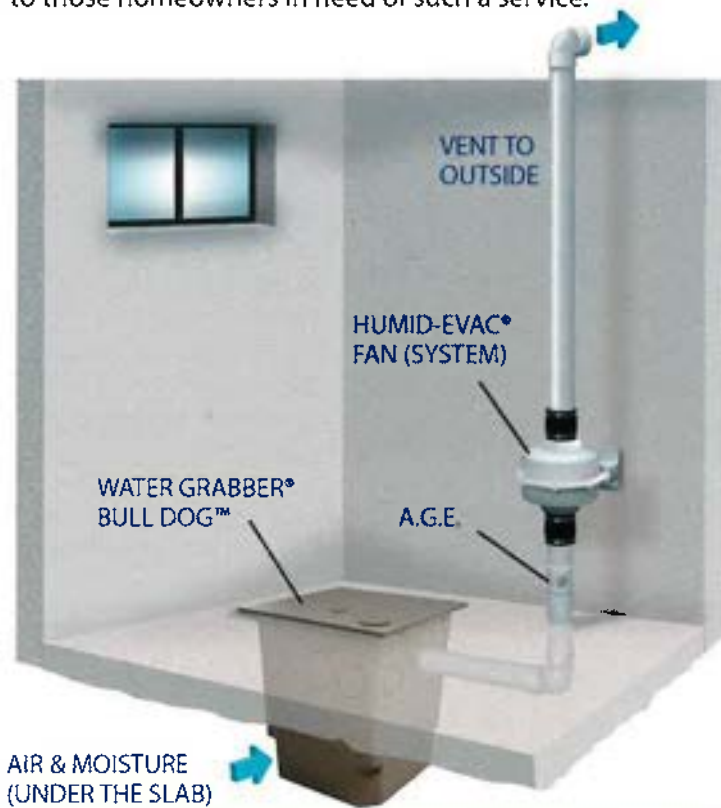

RESEARCHING THE FACTS:

Some agencies that have done research on sub-slab drying

1. Finnish research program on Environmental Health
 - Improves slab drying
 - Reduces moisture
2. Mass DEP, Northeast Region
 - Site Remediation
 - Remove contaminants from subsurface

3. North Dakota DOH

- Controls indoor moisture
4. Data Collecting "Preventing Mold Growth"
 - Up to 80% of moisture is from sub-slab & soil
 5. GEI Consultants
 - Effective sub-slab vapor control
 6. Colorado DOH&E
 - Reduces moisture from soil and reduces mold and mildew and other indoor air quality concerns.

7. Anecdotal Evidence (25 plus years experience)

- Reduces Dehumidifier condensate problems
- Changes in concrete slab color from drying
- Reduction in musty odors
- Less rust on metal and tools in basement
- 10%-20% reduction in slab vapor transmission at "turn on"
- 30% reduction in slab vapor

www.1800busydog.com



HYDRO-CRETE

2-PART DAMP PROOFING EPOXY COATING

The "Final Touch" in an unfinished area.

Stopping major basement water infiltration is a job for a specialist. The Water Trek Aqua Route® is usually the system for most problem basements. For years, dampness that appears on concrete that appears wet or damp creates an illusion of a "wet basement" and has been a focal point to fix. The Busy Dog® Hydro-Crete™ Sealer makes the concrete surface sealed, aesthetically pleasing and is a great "add on" for your water-proofed basement.

Coatings/epoxys and sealants are never a cure for a flooded basement.

2-PART DAMP PROOFING EPOXY COATING

1-800-BUSYDOG BT Hydro-Crete™ Sealer is a high strength, hydrophobic, breathing-type, two-component, modified epoxy coating manufactured from a balanced ratio of fillers and water extended resins and hardeners. Our exclusive formula combines flexibility with the hardness of epoxy resins.

During the curing phase, 1-800-BUSYDOG BT Hydro-Crete™ Sealer polymers cross-link to create a macromolecule of extreme durability to provide optimum resistance, severe below grade hydrostatic pressure, and other environmental conditions.



Damp proof treatment for concrete slabs.

The 1-800-BUSYDOG BT Hydro-Crete™ Sealer mixture penetrates deep into the surface capillaries, that when totally cross-linked, serve as a water insoluble lining on the sidewalls of the pores and voids in the substrate (making them water repellent). This lining robs the water of its capillary action-preventing moisture from entering through the masonry. A second coat, bonded to the previous coat, builds up sufficient density, cohesion and strength to render the surface pinhole free and impervious to

mass water penetration. On extremely porous surfaces, a third coat may be needed to touch up areas where porosity can still be seen. The Hydro-Crete™ should always be used in conjunction with our Water Trek system, creating an impenetrable combination.

1-800-BUSYDOG BT Hydro-Crete™ Sealer forms a positive, high quality, integral protective barrier against mass water penetration and is warranted if used with our Water Trek system. When minimum down time, high pressure resistance, coating strength and longevity are major factors in choosing coating suitability, BT Hydro-Crete™ Sealer can be specified for use on all types of damp interior or exterior, above or below grade, masonry surfaces including concrete, brick, various types of masonry block, mortar, stucco, adobe, cast-stone or sandstone.

1-800-BUSY DOG®



1-800-BUSYDOG BT Hydro-Crete™ Sealer:
Quality damp proofing protection for about the same cost of high-grade paint. Concrete and cement block are porous and can't stand up to the elements alone. The corrosive action of water passing through masonry literally eats away at these surfaces causing breakdown and seepage.

1-800-BUSYDOG BT Hydro-Crete™ Sealer actually penetrates masonry surfaces above and below grade for maximum protection.

No other concrete sealant works quite like 1-800-BUSYDOG BT Hydro-Crete™ Sealer. Unlike conventional sealers, 1-800-BUSYDOG BT Hydro-Crete™ Sealer penetrates the pores of the surface and cures for an unmatched bond, forming a permanent, reliable layer of protection that water cannot pass through. Should be used with the Water Trek system.

1-800-BUSYDOG BT Hydro-Crete™ Sealer resists peeling, blistering or flaking due to moisture, and because BT Hydro-Crete™ Sealer is an epoxy resin formula, it has excellent freeze/thaw durability, superior adhesion and high chemical resistance.

1-800-BUSYDOG BT Hydro-Crete™ Sealer blocks out the elements yet it allows concrete surfaces to breathe. Residual water vapor escapes before damage can occur inside the concrete. Tested up to 40 PSI (see Fed. Spec. TT-P-001411) with no visible seepage.

1-800-BUSYDOG BT Hydro-Crete™ Sealer is also a safe, solvent-free material that is easy to apply. Apply BT Hydro-Crete™ Sealer with brushes, rollers or airless spray gun. This zero VOC product requires no special precautions.

1-800-BUSYDOG BT Hydro-Crete™ Sealer is non-toxic and odor free. Clean up with warm soapy water.



Interior masonry coating spray applied.



Concrete slab protection used with Water Trek system.



Sealed basement walls used with Water Trek system on floor.

1-800-BUSY DOG®



Copyright © 2011 Busy Dog, Inc. All Rights Reserved.

Mud-Jacking

Is Your Concrete Sinking?

Solutions for floors, patios, stoops and more!

**1-800-Busy Dog
Basement
Technologies**
The Basement Specialists™
Basement Waterproofing

Does your concrete slab or basement floor have problem areas where sunken concrete has caused uneven surfaces and cracks to form? What about the patio, driveway, and sidewalk or walkways around the rest of the property? These conditions are usually associated with shifting, erosion, and a weak soil base. Fortunately there is a simple solution.



4 Ways Concrete Lifting is used to Repair Concrete

- Concrete slab repair
- Concrete porch repair
- Concrete floor leveling
- Repair cracked concrete floors



1-800-BUSY DOG®



**Mud-jacking, slab-jacking,
grout injection... concrete lifting?**

**1-800-Busy Dog
Basement
Technologies**
The Basement Specialists™
Basement Waterproofing



Call it mud-jacking, slab-jacking, grout injection or simply concrete lifting – they are one in the same. Whatever the case, the process entails drilling small holes through the concrete of affected areas and pumping cement grout underneath. As the mixture flows beneath the surface, voids and depressions are filled and the concrete is raised to the desired height.

New England's #1 Concrete Repair Company

We've been repairing concrete throughout New England for over 30 years. Since 1984 to date, we've been fortunate enough to acquire hundreds of thousands of happy customers. Whether you're a homeowner, commercial property owner, general contractor, engineer or architect – Basement Technologies is the best concrete repair company to address your needs. Contact us today for a free inspection, evaluation and repair estimate.

How Mud-Jacking Works

Basement Technologies uses a three-step lifting and leveling process to restore your sunken concrete back to its original level. Almost any lift can usually be completed in just one day without having to remove any structures (such as detached garages, sheds or fences) that sit on the slab. Backyards and other remote locations on a property can usually be easily accessed with our equipment so there is little or no disturbance to your landscaping.

How it Works:

Step 1: We drill holes into the concrete slab that is in need of restoration.

Step 2: Grout is carefully injected through these holes in the concrete slab to fill any voids between the slab and the ground surface. As the grout fills the area beneath the slab, the slab begins to slowly rise back to the desired level. Grout continues to be added underneath the slab until the entire slab reaches the full height.

We ensure that the proper slope is made to direct water away from the foundation. Establishing this proper surface grade also helps to prevent water from migrating underneath the slab and creating additional freezing and thawing conditions which may cause future settlement issues.

Step 3: Our team will patch the surface of the slab where the holes were drilled to give your slab a smooth uniform finish.

Sunken concrete driveways, sloped sidewalks and settled garages have all been recipients of new life from our concrete restoration process. We are so confident in our concrete service that we provide a full two year warranty.

1-800-BUSY DOG®



Basement Technologies[®] presents PaviX[®] CCC100

**1-800-Busy Dog
Basement
Technologies**
The Basement Specialists[™]
Basement Waterproofing

Exterior Waterproofing Without Digging

Waterproofing exterior special structures calls for special products. Parking garages, tunnels, pools and bridges are special structures.

PAVIX[®] CCC100 is a unique, water-based chemical product for moisture protection of large-scale concrete substrates against temperature and water associated problems such as thermal cracking, damage caused by repeated freeze and thaw cycles, chloride ion penetration, as well as alkali silica reactions.

PAVIX[®] CCC100 keeps treated concrete reasonably dry, thus helping eliminate most water and moisture associated problems by providing three effective mechanisms for concrete protection in all weather conditions — formation of two types of crystals and water repellency. In the presence of moisture, one type of crystal present in the product swells, blocking pores completely. The second type of crystal absorbs the extra moisture on the surface of the crystal preventing surface moisture on that crystal from diffusion to the concrete. These hydrophilic and hygroscopic properties provide double and durable protection against moisture penetration in concrete.

Advantages and Benefits:

- Provides long-lasting internal waterproofing and moisture blocking from positive and negative sides
- Excellent repelling property preventing water, jet fuel and oil penetration intrusion from the surface
- Resists aggressive chemicals such as acids, caustics, jet fuels and oil
- Protects reinforcing steel bars against corrosion without any negative effect on steel cathodic protection
- Enhances the adhesion property of joint sealant and concrete road markers
- Reduces alkali silica reactions (ASR), and eliminates silicate dusting
- Prevents penetration of chloride ions from de-icing salts
- Eliminates damage caused by repeated freezing and thawing
- Prevents concrete scaling
- Increases concrete hardness
- Seals and protects cracks up to 1/16th inch (1.5 mm)

Fields of Application:

- Airport runways
- Airport taxiways
- Aircraft parking
- Bridges
- Tunnels
- Concrete roads
- Parking lots
- Buildings
- Sea Ports
- Walkways



Concrete wall before, during and after PaviX treatment

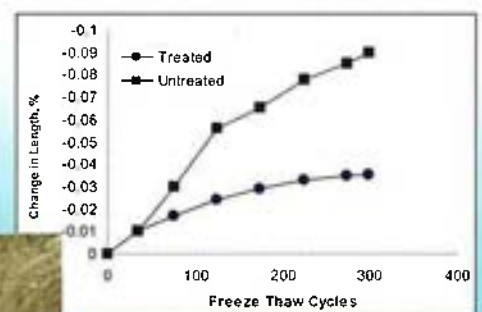

Freezing and thawing effect on treated and untreated samples



A Comparison with Competitor's Specifications

PERFORMANCE FEATURES	PONI® POWERGARD SYSTEM
Pumping Capacity (gal/hr @ 10 ft)	*Up to 3000 gal/hr with 1/3 Hp pump *Up to 5000 gal/hr with 1/2 Hp pump
Pumping Time Expandability	Multiple batteries in parallel increase pumping time
Battery Charger Capacity	20A multi stage charger
System Recharge Time	10 hours when using BC 27 group size battery
Installation Comparison	Works with pumping equipment that may already be installed
Versatility Comparison	Can be used with pumps of various capacities
Space Occupancy Comparison	Occupies no space in the sump pump

PONI® POWERGARD
Clean, Fully Automatic, Instant Emergency
Power For Sump and Immersible Pumps



Features and Benefits of PONI® POWERGARD

Operates with existing equipment translates into:

- *Optimum performance
- *Without the installation of additional pumps

Not restrictive to a single brand or pump style

Easy Hook Up

(No special tools or wiring necessary, plugs into standard wall outlet)

Automatic Power Transfer

(You do not have to be present to make it work)

Maintenance Free Operation

(Needs no fuel, has no moving parts)

Automatic Recharge

(You do not need to remember to recharge the battery)
(You do not need an additional battery charger)

Battery Monitor

(Notifies you when your battery needs changing)
(Informs you of state of recharge)
(Audible tone sounds prior to completion of battery drain)

Output Power Indicator

(Confirms that pump sentry is delivering power)

Silent and Clean Operation

(can be kept in home basement or utility room)

Enables the combination of column and submersible pumps without special additions

(no check valves or switches)

Comprehensive Instruction

Manual and Factory Support (Unconditional 2 Year Warranty on PONI® POWERGARD only)
(no warranty is implied for misapplication - see instruction manual for correct usage)



HERE IS HOW THE PONI® POWERGARD WORKS

PONI® POWERGARD is an innovative power station designed to operate your pump during a power outage. Figure 1 shows the Pump Sentry's simple interconnection between sump pump, battery and power line.

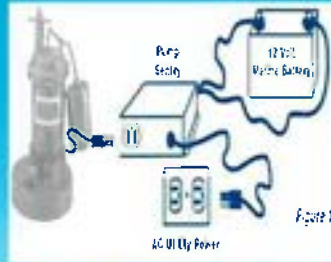

When electricity is present, the PONI® POWERGARD charges a 12-volt battery and monitors the power line.

At the instant a power failure occurs, the Pump Sentry converts the energy stored in the battery to AC power to operate your pump. When AC utility power is restored, the PONI® POWERGARD automatically switches your pump back to AC utility power, recharges the battery, and resumes monitoring the power line.

In the absence of electricity, PONI® POWERGARD will convert power from a deep cycle marine battery(ies) to operate a sump pump. Under typical duty cycle conditions, using a single BCI group size 27 battery, such operation can be maintained for approximately 20 hours. To obtain even more back up time, larger batteries or multiple battery banks can be configured (see Figure 2 for multiple battery parallel configuration). Back up time is directly proportional to battery capacity.

How to Calculate Operating Time During Power Outage

Operating time will depend on the following:

- 1) The size of the battery bank i.e. its total Ampere-Hour (A-hr) capacity is calculated by adding the A-hr ratings of all the batteries in the battery bank where the batteries are connected in parallel. (For Parallel Connection See Fig. #2)
- 2) The current draw for the pump in Amps (C). This can be read off the nameplate on the sump pump.
- 3) The average operating duty cycle of the system. The duty cycle of a system is the ratio of its "on" time to its "on" time plus "off" time. For example: If a pump will work for 10 seconds and is then off for two minutes (120 seconds) its duty cycle is calculated as follows:

$$\text{Duty Cycle} = \frac{10}{10 + 120} = 0.077 = D$$

Once (1) (2) and (3) are known, the operating time of the PONI Powergard can be calculated by the following formula:

$$T = \frac{A-hr}{(C \times 10 \times D)}$$

An example of a typical sump pump system with:

- 1) 1 Battery rated 90 A-hr, A-hr = 1 x 90
- 2) A sump pump that draws 9 Amps, C = 9
- 3) Duty cycle which operates 10 seconds "on" followed by 3 minutes (180 seconds) "off"; D = 10 / (10 + 180) = 0.053

$$T (\text{hours}) = \frac{1 \times 90}{(9 \times 10 \times 0.053)} = 19$$

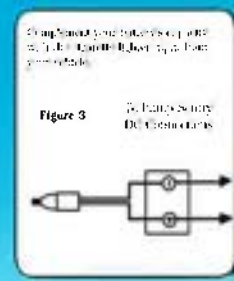
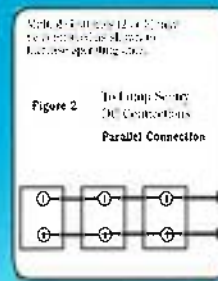

Battery Installation

Installation of batteries should be performed or supervised by a person knowledgeable of batteries and the required precautions. Keep unauthorized personnel away from batteries. For recommended batteries, use models conforming to Battery Council International (BCI) group size 27 or larger. Deep Cycle Marine Batteries are recommended. DO NOT use car batteries. Multiple batteries may be connected as shown in Figure 2 to increase back up time.

Battery Box

Your selected battery(ies) should be stored in a high quality plastic or metal battery box with a lid that is designed for the box.

Installation Location

In a typical installation, the PONI® POWERGARD should be mounted on the wall, above the sump pit or crock, and in accordance with all applicable local electrical codes. It should be in close proximity to a grounded AC outlet and the battery box (between 2 - 4 ft).

ELECTRICAL SPECIFICATION	822PS	1622PS
Input Volts	120 VAC; 60 Hz.	120 BAC; 60 Hz.
Maximum Continuous Output Power	1200 WATTS	11800 WATTS
Start Up Surge Capacity (3 seconds)	25 Amp.	33 Amp.
AUDIO INDICATORS		
Audible Alarm - Imminent Shutdown	When batter level has declined to 10.8V	
VISUAL LEDS		
Active When Lit	Indicates that power is present at the output receptacle	
Bulk Charge	High Recharge State	
Float Charge	Low Recharge State - Battery Almost Full	
Fully Charged	Batter is Full - Charging Suspended	
Replace Battery	Battery is Degraded from Long-Term Use	

1-800-BUSY DOG®



Copyright © 2011 Busy Dog. All Rights Reserved.

POWERHOUSE TURBO

POWERHOUSE TURBO 1/2 & 3/4 PUMPS

**1-800-Busy Dog
Basement
Technologies**
The Basement Specialists™
Basement Waterproofing

“DESIGN INNOVATION KEYS OUR SUPERIOR PRODUCTS”™

1-800-BUSYDOG Basement Technologies® focus has always centered on creating and improving our products to create reliable pumps and other accessories for the benefit of our customers. That begins by using premium components and designing pumps for maximum pumping capabilities, better energy efficiency and durability. The **POWERHOUSE TURBO** sump pump uses an energy efficient PSC motor, upper and lower ball bearings for quiet operation, and triple seals to ensure longer life. Our innovation has additionally created patented switches and controllers with state-of-the-art monitoring systems.

HIGH CYCLE PRIMARY PUMP CONTROLLER, DUAL FLOAT SWITCH WITH BUILT IN MONITORING:

- It's best to utilize the solid state circuitry in our controller for high cycling situations, because some applications frequently demand the pump turn on and off
- Solid state circuitry has no moving parts to wear out or break
- Utilizes reliable, proven "Triac" electronic technology; the same technology used in microwaves and other appliances for years
- Includes caged dual micro reed float switch for protection
- Monitors will sound an alarm when:
 1. AC power has failed
 2. 9V battery is low, or slide switch is off
 3. Pump or plumbing problem is detected
- System operating light (flashes)
- Adjustable run time from 5-45 seconds
- Output terminals can connect to security system or auto dialer
- Float switch can be unplugged from the controller for easy installation
- Activates pump weekly to exercise/extend pump life



1-800-BUSY DOG®



It's a "powerhouse" specifically designed and engineered to handle the most severe basement waterproofing problems.

BUSY DOG "POWERHOUSE TURBO"

ENERGY EFFICIENT

- Uses as low as 3.8 amps (compared to 10+ amps on other pumps)
- Pump will pay for itself in energy savings
- When running 5 minutes per hour, pump will save the homeowner an average of \$52.42 per year*

DUAL FLOAT SWITCHES WITH PROTECTIVE CAGE

- 2 floats for added redundancy
- Won't get "hung up"
- Protective cage prevents debris or wires from interfering with float operation

DURABLE CONTINUOUS DUTY PUMP

- Cast iron / cast aluminum construction
- Dual ball bearings
- Energy efficient permanent split capacitor (PSC) motor
- Dual seals to protect the motor
- Water cooled motor (no cooling oil)
- Stainless steel fasteners
- 10 ft. pump cord

THE BUSY DOG "POWERHOUSE TURBO" PUMP uses substantially fewer amps than shaded pole pumps from other manufacturers.

That means they are considerably less expensive for homeowner to operate. Superior energy efficiency translates to lower energy bills for the homeowner. The average cost savings earned when using a "POWERHOUSE TURBO" sump pump is \$52.42 per year* reducing the homeowners energy bills!

**Based on an average sump pump run time of five minutes per hour for one year. The POWERHOUSE TURBO uses 3.8 Amps @ 10'. The estimated average of a 1/2 HP shaded pole motor is 9.5 Amps. Average electric cost per-kilowatt-hour is \$0.12*

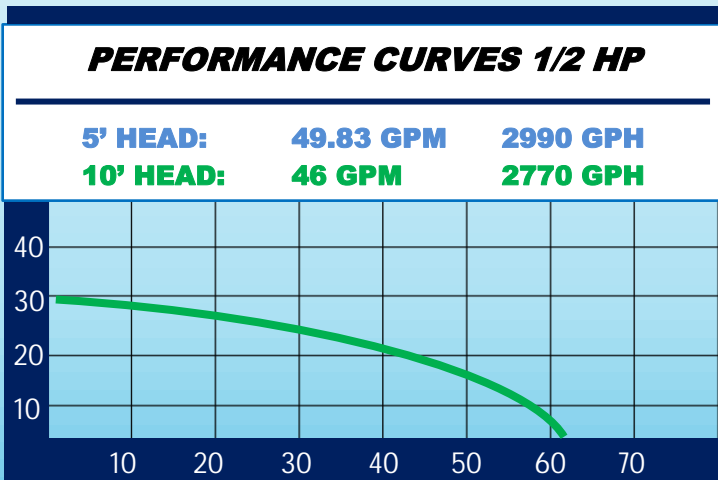

PRODUCT COMPARISONS

IT IS IMPORTANT THAT CONSUMERS ARE FULLY EDUCATED ON AVAILABLE BASEMENT WATERPROOFING SYSTEMS. WHEN FULLY EDUCATED, THE CHOICE IS EASY.

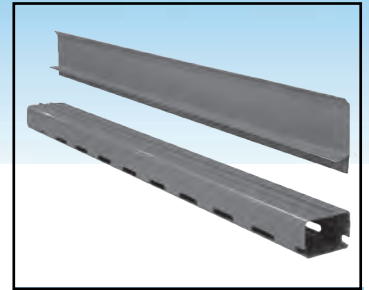
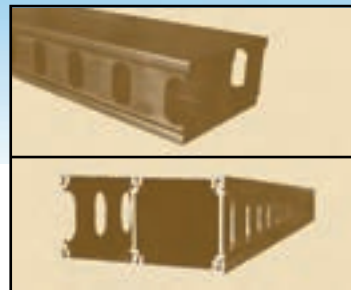
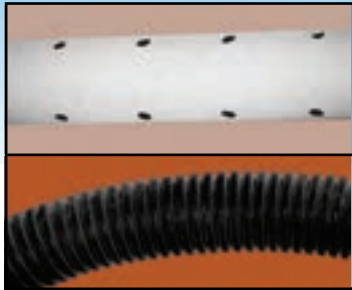

**PVC Pipe /
Corrugated Pipe
& Stone System**

**Pre-set
Depth
System #1**

**Pre-set
Depth
System #2**

**Patented
Water Trek Aqua
Route® System**

<p>1. Pipe can be purchased in any store.</p>	<p>Conduit supplied by manufacturer. Training necessary.</p>	<p>Conduit supplied by manufacturer. No proven track record – limited history on proven performance.</p>	<p>Conduit supplied by manufacturer. Training necessary.</p>
<p>2. Anyone can install, non-specialized.</p>	<p>Only manufacturer's representatives can install – specialized.</p>	<p>Anyone can install, but specialized.</p>	<p>Only fully trained manufacturer's representatives can install – specialized.</p>
<p>3. System installed to 12" depth under floor.</p>	<p>System installed only 4" under floor.</p>	<p>Manufacturer unclear how to install – all trial and error – possible failure. "Rolled product"</p>	<p>System installed as needed. Depth will be custom tailored – not predetermined.</p>
<p>4. Visible gap may be left after concrete installed.</p>	<p>Has 3/8" gap on wall, may catch water from wall.</p>	<p>Manufacturer does not specify how to handle – big question dependent on installer.</p>	<p>Has 1/16" – 1/4" gap on wall – designed to catch water from wall.</p>
<p>5. Limited warranty.</p>	<p>Warranty available.</p>	<p>Limited warranty.</p>	<p>Warranty available.</p>
<p>6. Circular holes / small slotted holes on pipe.</p>	<p>Circular holes in back only.</p>	<p>Double chamber does not allow for self-cleaning – system holes tend to clog. Does not handle proper water volume. Allows stone into system.</p>	<p>Specialized holes in front and back.</p>
<p>7. Can be used for interior arteries and floor cracks.</p>	<p>Cannot be used for interior arteries.</p>	<p>Can be used for interior arteries – but tends to clog. Does not wash.</p>	<p>Can be used for interior arteries and floor cracks.</p>



AVAILABLE BASEMENT WATER PROOFING SYSTEMS PRODUCT COMPARISONS

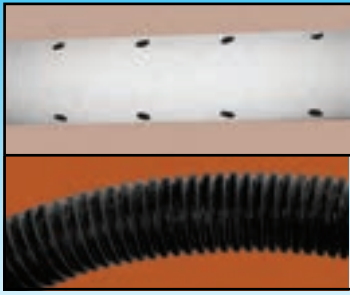

PVC Pipe /
Corrugated Pipe
& Stone System

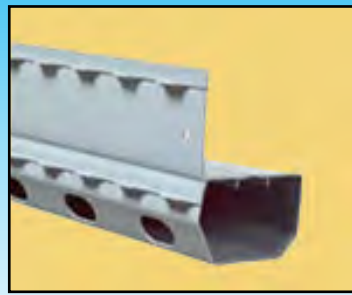

Pre-set
Depth
System #1

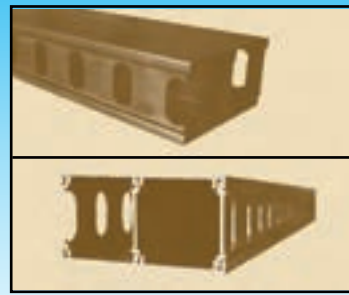

Pre-set
Depth
System #2

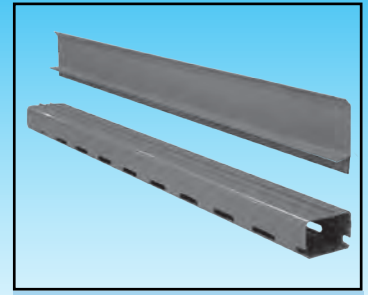

Patented
Water Trek Aqua
Route® System

8. Pipe purchased in stores; non-specialized contractors can install; service problems may affect warranty.	Specialized company installs, honoring warranty.	Conduit can be purchased by any contractor. No proven track record. New experimental product.	Specialized company installs, honoring warranty.
9. Pipe easily clogs with dirt and mud caused by significant depth. Addresses "insignificant water".	System designed to be installed on footing only. If installed on dirt, may clog.	Pipe easily clogs due to chambers. Does not self-wash. Designed to "get around" existing patents.	System can be installed on footing or in front – will not clog due to holes in front and back tends to self-wash.
10. Significant depth activates pump unnecessarily. Pumps do not last as long.	Addresses water threatening floor but not in front of footing due to holes on inside only.	Addresses water from footing and in front but only handles 1/2 the flow and can clog.	Addresses water threatening floor surface in front and back of footing. Pumps will last longer.
11. Depth of installation may cause structural problems. Under wash of footings.	No structural threat.	Unknown depth. Untested new product.	No structural threat.
12. Job is very messy; trauma to homeowner and basement.	Job is cleaner, less stressful, less time consuming.	Tends to take longer due to "snap together" interior construction of product. Comes in a roll to save contractor money.	Job is cleaner, less stressful, less time consuming.
13. Sump location may vary.	Sump location limited to lowest spot.	Sump location limited to lowest spot.	Sump location customized to individual application.
14. No ridge on top – cannot attach to concrete.	No ridge on top – cannot attach to concrete.	No ridge on top – cannot attach to concrete.	Ridge on top will attach firmly to concrete.
15. Flange on top can vary.	Flange on top has 3/8" gap.	Variable flange – no consistency.	Flange on top fits tight to wall but allows water from wall cracks or windows to enter system. Prevents odors.
16. Holes on front and back or all around pipe. Excessive depth may allow easy clogging.	Holes on backside only; does not self-wash; does not address water in front of footing.	Open conduit cannot self-wash. Conduit only handles 1/2 volume – tends to clog.	Holes on front and back tends to self-wash and address water in front of footing as well as, footing/wall joint.

AT BUSY DOG BASEMENT TECHNOLOGIES EDUCATION IS OUR BEST SELLING TOOL – TO PROTECT YOUR MOST VALUABLE POSSESSION ... THE CHOICE IS EASY!

www.1800busydog.com®



Beauty Is In The Eye Of The Beholder . . . Behold!!!

Square, level and plumb are how homes are built. We think the liner should look just as handsome as your home and not like a plumbing (circular) fixture.



Rigid high density polyethylene injection molded to be stronger and more durable than structural foam which most others use.



Sealed lid Water Grabber® Bull Dog™ with Ranger™ drain. The Ranger™ drain can handle pipe bursts and funnels directly into our liner.



Sealed lid for top or side discharges. Our lids are colored gray to match the concrete on the floor and able to be sealed tight, eliminating radon gas, rodents and insects from entering your living space. Side discharges are often excellent to accommodate for carpet or flooring being placed over the top.

Specially made for 1-800-Busy-Dog® Dealers and our customers.



Predrilled holes in side of liner, smaller than the surrounding gravel, keep stones and debris out of your liner and away from the pump.



Lid can support upwards of 450 lbs. Excellent to install carpet or flooring directly over.



3" knockout to accommodate 3" pipe that houses wires for a sealed lid Water Grabber® liner.

4" knockouts to accommodate the Water Trek Aqua Route® to Water Grabber® connectors to drain the perimeter system directly to our liner. Colored Gray to match your floor.



Top shelf enables our unit to house 2 pumps in the same liner. Redundancy is key for waterproofing. We can install 3 pumps - 2 primaries and 1 backup and also offer D/C backups for the primary pumps creating a virtual 5 pump system.

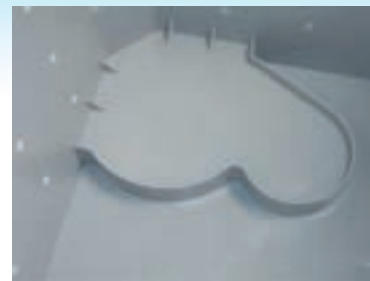

Shelf for bottom of liner that raises the pump about 1-1/2" to help ensure dirt does not "clog" our pumping unit.



1-1/2" cutouts to accommodate 1-1/2" discharge line for a sealed lid and another for the Ranger™ drain mounted (countersunk) in the concrete to drain water if a pipe bursts in the basement.

Square, level and plumb are how homes are built. We think the liner should look just as handsome as your home and not like a plumbing (circular) fixture.



Others try to copy, but fall short.



1-800-Busy-Dog® uses only the best. 1-800-Busy-Dog® pumps are used in our Water Grabber® Bull Dog™ liner. Has WiFi Compatibility.



Heavy-duty Stallion Eliminator Battery Backup Unit uses a third pump in our liner. With additional direct, current backups has five pump capability. With possible WiFi Communication.



One-On-One, There Is No Comparison

Available Sump Pump Liners For Basement Waterproofing Systems

Product Comparisons



**Retail
(Hardware Center)
Sump Pump Liner**

Sump Pump Liner

Sump Pump Liner

Sump Pump Liner

Sump Pump Liner

**Water Grabber®
Bull Dog™
Sump Pump Liner**

Sump liner can be purchased anywhere. Looks like an open sump pit and holder.	Sump liner can be purchased from manufacturer directly. Looks like a sump pump holder.	Sump liner can be purchased from manufacturer's reps only. Looks like a sump pump holder.	Sump liner can be purchased from manufacturer directly. Looks like a sump pump holder.	Sump liner can be purchased directly. Construction weak-very shallow and not able to handle large volumes of water. Side pipe discharge hard due to shallow pit.	Sump liner can be purchased by manufacturer's reps only. Does not look like a sump. Pump looks neat and square.
Liner may or may not have inlets for water. Lid not sealed allows gas, rodents and insects into basement.	Liner may or may not have inlets for water.	Liner has inlets for water. Sealed lid.	Liner has inlets for water. Sealed lid.	Inlets too big. Influx of water can overwhelm pump. Allows stone in. Manufacturer supplies "mesh" product to stop stones and debris.	Liner has inlets for water. Sealed lid only. Specialty contractor must install. Must be certified by company - intense training.
Does not have inlet for system. Has to be field cut.	Does not have inlet for system. Has to be field cut.	Has special fitting to allow water into sump liner from perimeter system.	Has special fitting to allow water into sump liner from perimeter system.	Does not have inlet for system. Has to be field cut. Liner is shallow - easily overwhelmed.	Has special fitting to allow water into sump liner from perimeter system.
Can be installed by anyone. Possible under excavating of dirt under footing.	Can be installed by anyone.	Installed by manufacturer's representative only. Can also be obtained through certain plumbing suppliers.	Installed by manufacturer's representative only.	Can be installed by anyone. Liner is shallow allowing large volume of water in at once - pump easily overwhelmed. Can allow dirt in from under footing.	Installed by manufacturer's representative only. Under excavation of footing unlikely due to size of holes and system's custom design.
Can house multiple pumps. No Stands available.	Can house multiple pumps. No Stands available.	Can house three pumps. Manufacturer supplies custom stands.	Can house three pumps. Manufacturer supplies custom stands.	Only one primary pump may be installed in liner. Battery backup just fits - too high and easily overwhelmed.	Can house multiple pump setups. Custom stands inherent and supplied by manufacturer.

SUMMARY	SUMMARY	SUMMARY	SUMMARY	SUMMARY	SUMMARY
<ul style="list-style-type: none"> • Can be installed by any non-professional • Looks like an ugly open sump pit • Gas, rodents & insects can enter living area • No stands available for multiple pumps 	<ul style="list-style-type: none"> • Can be installed by any non-professional • Looks like a sump pump holder • No stands available for multiple pumps 	<ul style="list-style-type: none"> • Mfg. reps can install • Can house up to 2 pumps • Stand available • Inlets for system • Looks like a sump pump holder 	<ul style="list-style-type: none"> • Mfg. reps can install • Can house up to 3 pumps • Stands available • Inlets for system • Side discharge not standard • Looks like a sump pump holder 	<ul style="list-style-type: none"> • Anyone can purchase • Inlets too big. Use of mesh to compensate for "milk crate" construction • No inlets for system • Too shallow - can easily be overwhelmed • Looks like a milk crate in floor 	<ul style="list-style-type: none"> • Square, level and plumb • Unit does not look like a pump holder • Fits perfectly in corner • Blends with color on floor • Pumps and backups available • Special holes to accommodate perimeter system • Can only be installed by qualified "licensed" dealers • "No pipe" look available • Sealed lids



PUMP WiFi COMPATIBILITY OPTION

BE ALERTED OF A PUMP PROBLEM IN YOUR BASEMENT WHEN AWAY FROM YOUR HOME

Our highcycle pump, the Powerhouse Turbo, now comes with Wi-Fi capability as an option.

The new “Wi-Fi capability” catapults us into a new age of reliability and accountability. If you have a power outage or pump failure,

YOU CAN NOW BE AUTOMATICALLY ALERTED!

1-800-Busy Dog Basement Technologies™ focus has always centered on creating and improving our products to create reliable pumps and other accessories for the benefit of our customers. That begins by using premium components and designing pumps for maximum pumping capabilities, better energy efficiency and durability.

Powerhouse Turbo pumps come with three components:

- 1) Caged dual micro reed float switch, designed for high redundancy for storms
- 2) Controller Box (hooked up to float switch) utilizing solid state circuitry designed for highcycling capability, which is what you need in a basement that has a pumping unit – utilizing “triac” electronic technology
- 3) The Powerhouse Turbo pump cast iron, dual ball bearing, permanent split capacitor, with dual seals to protect the motor, is water cooled with 10 foot cord

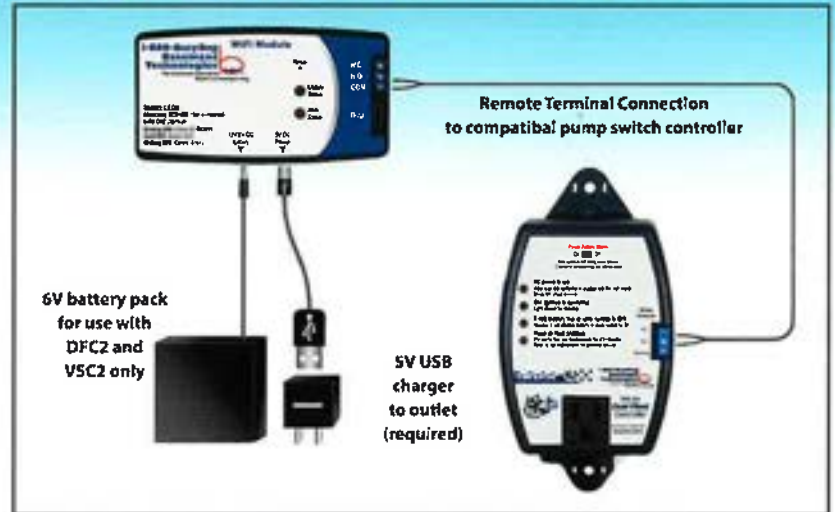

1-800-BUSY DOG®



The basic perfect pumping unit was not enough. We partnered with an electronics company that developed the electronic Wi-Fi system and put it on the Powerhouse Turbo.

The Wi-Fi capability has been added as an optional add on feature. If a homeowner chooses to incorporate it into their system and lifestyle, the Wi-Fi module can be purchased with a tutorial on how to connect it to your cell phone or device to alert you of a power outage or pump failure when you are away from home.

AUTOMATICALLY TELLS YOUR "DEVICE" OF A PUMP ISSUE

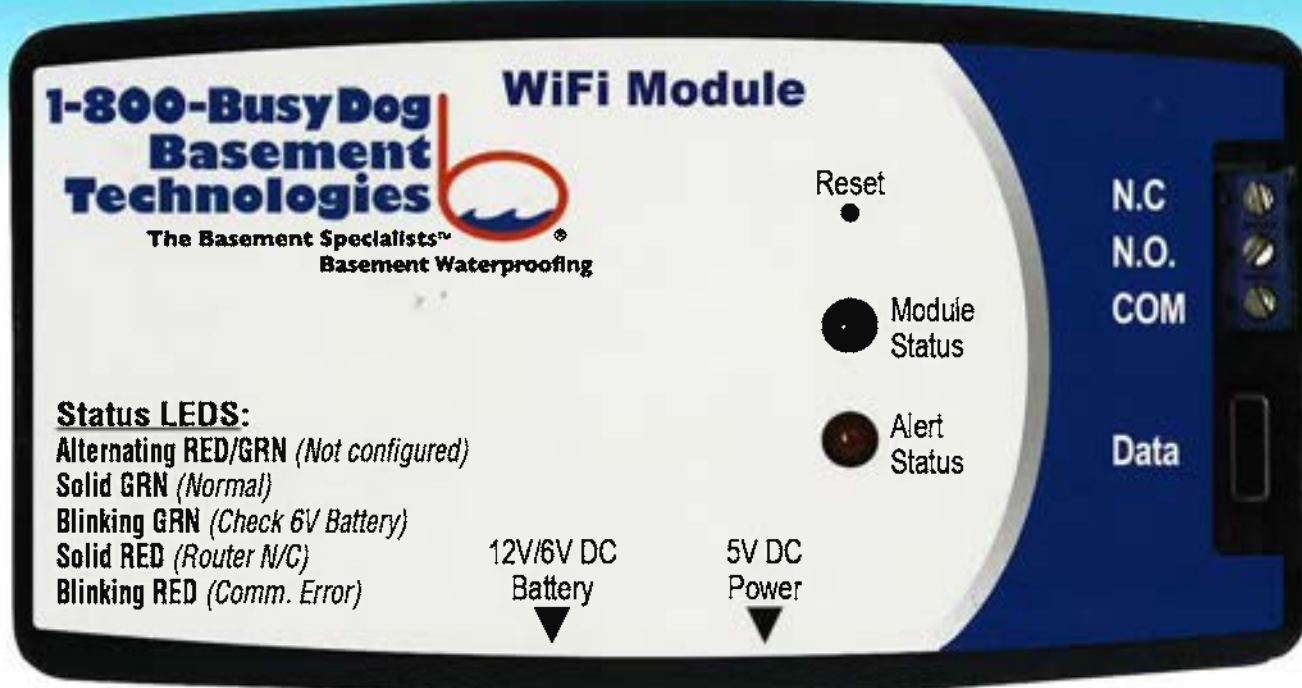

BUSY DOG POWERHOUSE TURBO CONSTRUCTION

1. Permanent split capacitor increases energy efficiency
2. Cast iron/cast aluminum housing
3. Electroplated steel strainer
4. Shaft
5. Upper and lower sealed ball bearings provide quiet operation that homeowners appreciate
6. Water cooled (no cooling oil)
7. Thermally protected
8. 1-1/2" outlet
9. Engineered polymer impeller
10. Pumps up to 1/2" solids
11. High capacity float switch
12. Controller box on wall to installation pump



1-800-BUSY DOG®



Radon Mitigation

Basement Technologies:

Installing Radon Mitigation Systems for close to 30 years.

1-800-Busy Dog
Basement
Technologies
The Basement Specialists™
Basement Waterproofing

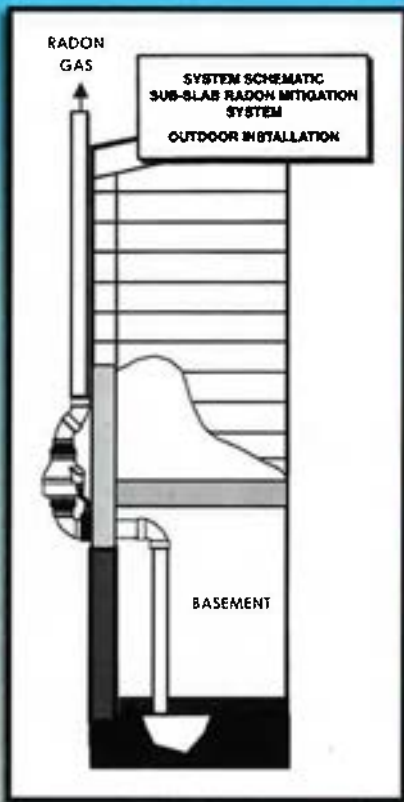

THERE ARE 3 POSSIBLE ROUTES FOR YOUR RADON ELIMINATION PIPE INSTALLATION:

- Exterior
- Interior
- Garage route

EXTERIOR ROUTE:

The most common is exterior with fan mounted on band board of home and exit point to eave line 10 feet away from adjacent opening or 2 feet above if within ten feet.

INTERIOR ROUTE:

This is usually through the house through stacked closets. The fan is mounted in an UNCONDITIONED attic space and penetrates the roof.

GARAGE ROUTE:

We penetrate through the garage with a fire ring in case of fire. The fire ring and pipe are mounted in an UNCONDITIONED garage roof.

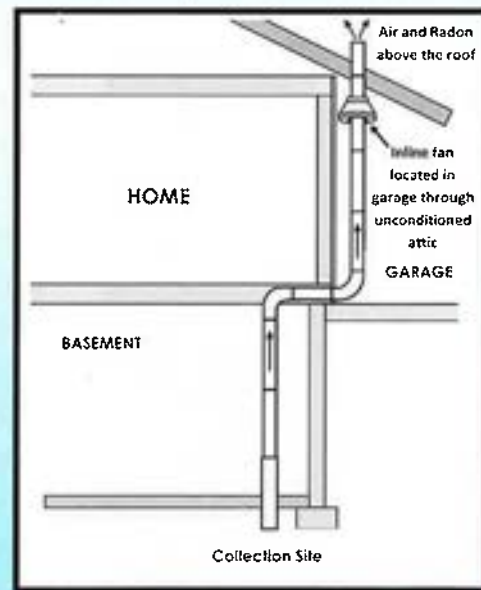
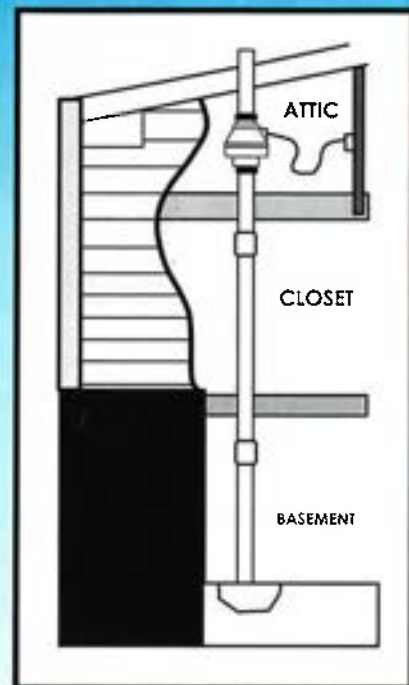

WHAT ARE "DROP POINTS"?

In radon system the low pressure "field" is established by the introduction of suction under slab. The "communication" is the continuity of pressure under the slab that draws the radon gas and moves it toward the "collection point" – The collection point is simply the area the slab is penetrated and the pipe is installed. The pipe creates a vacuum and draws the radon into the pipe and to the exit point at eave line or roof.



WHAT IS A MANOMETER?

The manometer is a "u-tube" that measures suction in water column inches and is mounted at eye level over each collection point.



1-800-BUSY DOG®



WHY ARE THERE DIFFERENT TYPES OF FANS?

There are multiple fans that can be obtained but after all is said and done there are only two distinctions:

1) High volume and 2) High suction.

High volume fans are usually for newer construction applications where there is excess of stone under the slab and in order to create a field of suction

there is a necessity to move large volumes of air that is due to excellent communication. If the volume of air is not moved quickly the radon gas can make it form under the slab into the habitable area.

High suction fans are generally for older construction where there will not be great communication under the slab (less stone, more dirt). We need to "draw hard" for a field of communication under the slab.

SOME BASIC GUIDELINES FOR RADON MITIGATION:



Exterior Installation

- Exit points: Ten feet from any adjacent openings – 2 feet above any openings that are within ten feet
- Be aware of rain water entry
- Pipe attached to home every 6-8 feet on vertical rise
- Manometer at all collection points
- Clear labeling of all interior pipes stating "radon system" and listing license number
- Labeling of dedicated circuit for radon fan
- Radon fan hard-wired to panel
- Communication and back draft tests done before mitigation leaves



Interior Garage or House Roof



Through Unconditioned Attic

Basement Technologies: Installing Radon Mitigation Systems for close to 30 years.



1-800-BUSY DOG®



Basement Technologies® presents SOFIX® CCC700

**1-800-Busy Dog
Basement
Technologies**
The Basement Specialists™
Basement Waterproofing

Interior Waterproofing Without Digging

Waterproofing exterior special structures calls for special products. Parking garages, tunnels, pools and bridges are special structures.

SOFIX® CCC700 is a unique, colorless, odorless, clear, one-of-a-kind, water-based crystallization product that penetrates deep into concrete, specifically designed to permanently block moisture and vapor transmission. Application of the SOFIX® CCC700 system blocks moisture and vapor movement through concrete and masonry substrates within 24 hours and can be easily applied by spraying or rolling to concrete substrates that are 7 days or older. The SOFIX® CCC700 is formulated to enhance deep penetration into the concrete substrate through capillary action. The product components migrate deep into the concrete substrate to form hygroscopic and hydrophilic crystalline material which permanently blocks the concrete and masonry substrate pores. Even under the influence of constant hydrostatic pressure, the crystallization continues to fill and block the migration of moisture through the concrete substrate and continues while moisture is present. The product becomes inactive during dry conditions and is fully reactivated when moisture or moisture vapor are present. The unique "reactivation" is key in providing permanent waterproofing protection for any concrete or masonry substrate. The product protects, preserves and waterproofs without any surface film formation or color change.

Product features:

- High moisture, vapor blocking performance
- Single component
- Easy application
- Penetrates concrete sealing voids, capillaries and cracks up to 1/16th inch
- Multiple functions: blocking of moisture and increases the adhesion of coatings and paints
- Non-toxic
- Cost effective
- Resist hydrostatic pressure
- Internal and external application
- Treatable materials: concrete, concrete block, mortar, plaster, stucco, terrazzo, exposed aggregate and any sand, aggregate cement combination



**Magnification
of PavIX/Sofix
crystals that
block moisture
transmission**

Fields of application:

- Concrete floors
- Foundations and slabs
- Reservoirs
- Industrial plants
- Swimming pools
- Subway tunnels
- Elevator pits
- Walls and flooring in parking garages



Elevator pit flooded by ground water seepage



Elevator pit after Sofix® 700 and CCC 150 treatment





THE ULTIMATE IN BATTERY BACKUP UNITS

Basement Technologies' Stallion Eliminator® battery operated backup sump pump is designed to backup primary residential sump pumps in case of pump or power failure. A must for those installations where an inoperative sump pump can not be tolerated. Separate float switch and built-in alarm automatically starts the backup system and activates a warning buzzer to

protect against high water damage and warns of primary pump failure.



Stallion Eliminator® Pump and Float Switch

Storms, power outages and unforeseen mechanical failure are all possible realities. We recommend every Basement Technologies' customer plan for the unforeseen.

- Features**
- Battery powered sump pump runs automatically during a power outage.
 - Provides a backup to your standard sump pump in case of power failing or mechanical issue.
 - Automatic start-up during high water levels inside the sump.
 - Self charging
 - Indicator lights on charger
 - Alarm sounds when pumping and activated.



The charger's indicator panel w/meter and test switch.

An accepted reality in basement waterproofing is that all reliable basement waterproofing systems are based on a pumping unit. Basement Technologies' primary and secondary pumping units are the best in the world but pumping units are run on electricity and are a mechanical device that may come unplugged, trip a circuit, or shut off. Basement Technologies recommends Battery Backup Units and secondary pumps on all pump locations. The Stallion Eliminator® is designed to be the best Battery Backup Unit on the market.



Charger. Battery. Power.



Applications

The Stallion Eliminator® is designed to provide emergency backup service for the primary pump in the event of a power outage or pump failure. The pump will also operate if the main pump can not keep up with water inflow.



The Stallion Eliminator® w/Water Grabber® sealed lid sump hiding discharge pipe for a clean look.

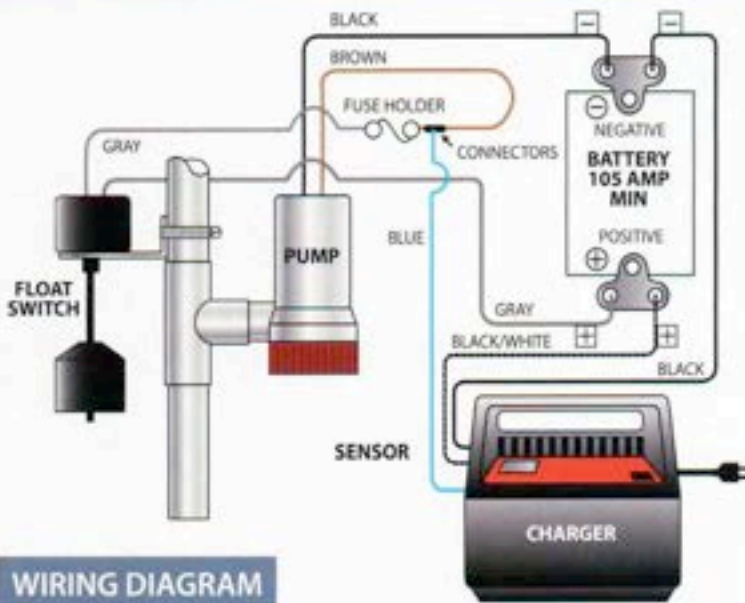

WIRING DIAGRAM

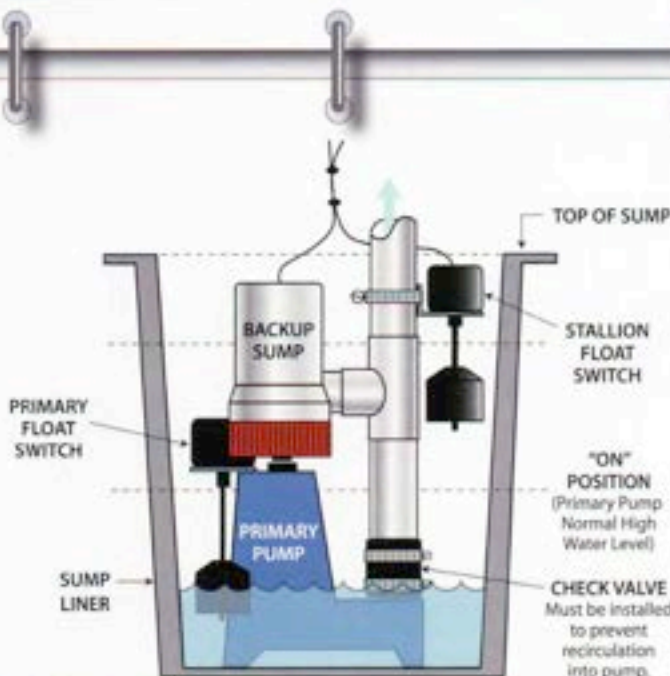

STANDARD INSTALLATION

Specifications

- 12 volt pump
- Float switch
- 10 amp battery charger
- Check valve
- Pipe fittings
- Battery box
- System requires minimum 105 amp deep cycle marine battery (not included).

Authorized Dealer
Basement Technologies
 The Basement Specialists™
 Basement Waterproofing

Improving Basement Waterproofing From The Ground Up™



STALLION ELIMINATOR II®

THE ULTIMATE IN BATTERY BACK-UP UNITS

1-800-BUSYDOG BASEMENT

Technologies'® Stallion Eliminator®II



battery backup sump pump system is designed to give the homeowner peace of mind, when protecting their basement from flooding. Eventually all sump pumps can fail for different reasons. The backup system switches automatically to battery power when AC power fails. It also has a secondary dual float switch for added reliability and an alarm system that monitors pump and power conditions. The system will sound an alarm when the

AC power is out, a circuit breaker has blown, battery is discharged, and when the backup pump is activated.

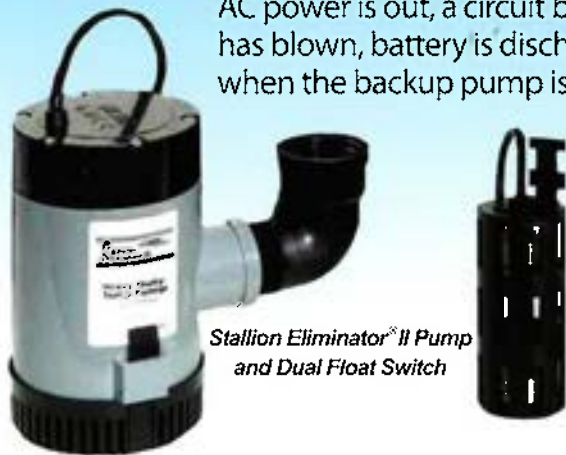

Stallion Eliminator®II Pump and Dual Float Switch

Increased Capability without failure!

Features

- Switches automatically to battery power when AC power fails
- Pumps automatically when water volume exceeds the capacity of the main AC pump
- 13 amp charger allows pump to run directly on AC power
- Pumps on AC power when available as well as battery power
- Automatically tests the pump weekly to exercise and extend pump life
- Monitoring of battery and pump conditions
- Caged dual float switches for added reliability
- Remote terminals to communicate with a home security, home automation or other device
- Designed for use with Maintenance or Maintenance free battery

Basement Technologies®
The Basement Specialists™
Basement Waterproofing



The controller's indicator panel has:
Test/Silence Button
Warning Alarms
Battery Power Level
Battery Type Switch



Your basement's protection relies on the dependability of your sump pump. 1-800-BUSYDOG Basement Technologies' pumps are the best in the world, but any sump pump can fail for a number of reasons, such as storms, power outages, and unforeseen mechanical failure. Because of this, Basement Technologies recommends Battery Backup Units and secondary pumps on all pump locations. The Stallion Eliminator® II is designed to be the best Battery Backup System on the market.

"Storms, power outages, and unforeseen mechanical failure are all possible realities. We recommend every Basement Technologies' customer plan for the unseen."



1-800-BUSY DOG®



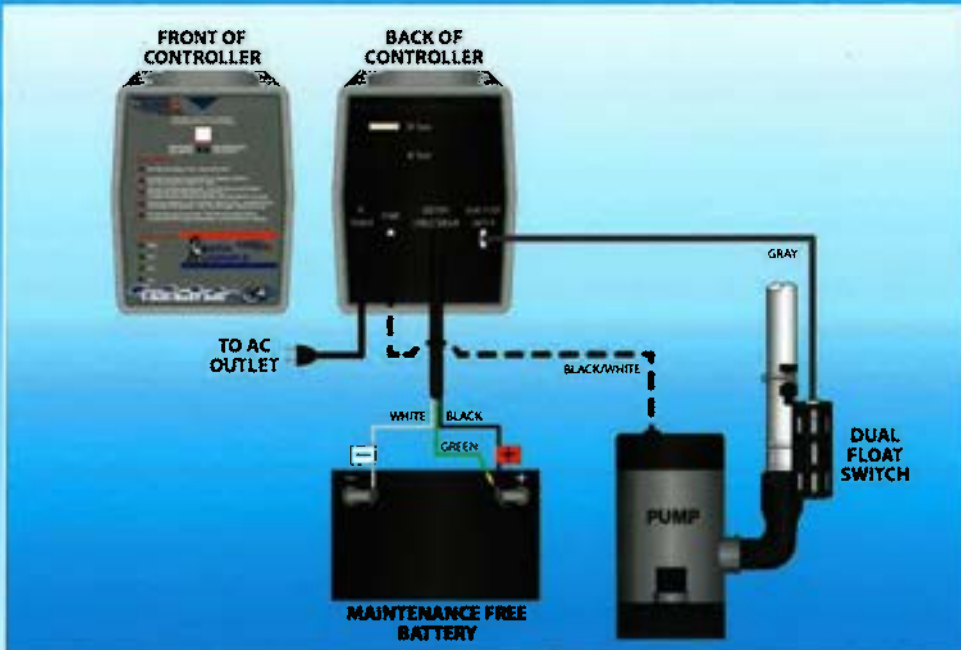

Applications

The Stallion Eliminator® II is designed to provide emergency backup service for the primary pump in the event of a power outage or pump failure. The pump will also operate if the main pump can not keep up with the water inflow.

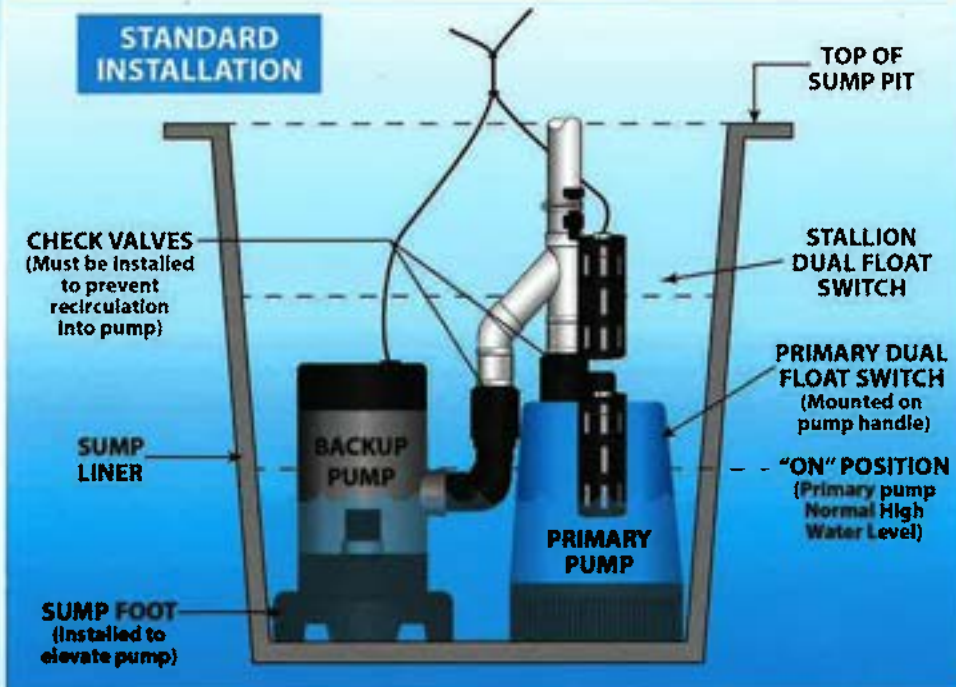

The Stallion Eliminator® with Water Grabber® sealed lid sump hiding discharge pipe for clean look.

Specifications

Caged Dual Float Switch

- Two micro reed activated floats for added reliability
- Protective cage prevents debris from interfering with floats
- Activation level is adjustable

Pump and Controller

- 12 volt pump
- 13 amp charger
- Check valve
- Pipe fittings
- Battery Box

- Automatically switches to battery power when AC fails
- Monitoring of pump and battery conditions
- Remote terminals for connection to a home automation, security system or other device
- Recharges battery automatically
- Designed for Maintenance and Maintenance Free battery

1-800-BUSY DOG®



TECHNI-CRACK®

**1-800-Busy Dog
Basement
Technologies**
The Basement Specialists™
Basement Waterproofing

HYDROPHOBIC MEMBRANE PROCESS FOR POURED WALL CRACKS



Poured foundation wall cracks generate water onto the basement floor.

The Techni-Crack® product uses a patent pending hydrophobic membrane with an injection process. If water enters from the treated crack (and most, if not all water is prevented from entering by the injection process) it will be repelled efficiently into the system below. Current foundation crack injection methods do not meet 1-800-Busy Dog Basement Technologies® standards. The need to develop and implement a better product was achieved with our introduction of Techni-Crack®. Ask your 1-800-Busy Dog Basement Technologies® representative how our Techni-Crack® hydrophobic membrane process can repair your walls permanently.

Poured Foundation **WARRANTEED**
Wall Seepage Solution

1-800-Busy Dog Basement Technologies® recognized a need to have a flawless wall crack waterproofing method. The available solutions on the market today do not compare to our patent pending Techni-Crack® method.



Optional polyurethane injection stops water from the outside of the wall (for really severe leaks).

One part polyurethane sealant on the crack.



We apply hydrophobic gel on the back of the Techni-Crack® membrane and apply it to the wall. We then tie it into the Water Trek Aqua Route® system or drywell.



Finishing the Techni-Crack® membrane with sealant.



Finished Techni-Crack®

1-800-BUSY DOG®





Poured foundation warranted wall seepage solution.

1-800-Busy Dog Basement Technologies® has been using polyurethane and epoxy injection for years. Although these types of injections are successful, problems can develop over time. Concrete walls and soil expand and contract, which can generate the need for further repair. 1-800-Busy Dog Basement Technologies® saw the need to go a step further and develop a “fool proof” method for foundation crack waterproofing. The Techni-Crack® process eliminates the need for further repairs and provides a lifelong solution. The hydrophobic compound applied to the back of the membrane repels any water quickly and efficiently directs it to the system below. It has proven to be the most reliable method available on the market today.

It just works better!

Inventing a better method to seal cracks in poured foundation walls that would not require constant repair, was important to 1-800-Busy Dog Basement Technologies' R&D Division. The resulting process and product simply work better. The primary “seal” put in place during the process works alone, yet with the addition of the Techni-Crack® hydrophobic membrane, homeowners can be assured they have a worry free solution in place.

- 1 Seal the crack with a special concrete sealant. This sealant will stop the water leak. For real problem leaks, a polyurethane injection can be added to our process.

Stops The Water From Coming In

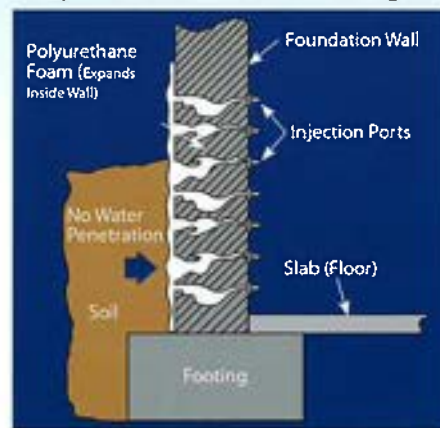

- 2 Install Techni-Crack® hydrophobic membrane with our special hydrophobic gel on the crack and seal with our special concrete sealant.
- 3 Tie the Techni-Crack® membrane and sealant into our Water Trek Aqua Route® system or a drywell under the floor.

For protection with a warranty, our Techni-Crack® serves as a lifelong solution. After many years, due to concrete shrinking, swelling and settling, there is a chance that a small leak may reoccur. With the Techni-Crack® application, this problem is resolved.

1-800-BUSY DOG®

www.1800busydog.com

1(800) 287-9364



WATER GRABBER® BULL DOG™

The Pump That Does Not Look Like A Pump

Install Value in Your Home!

Homes are built square, level and plumb ... *not* circular. Why have a circular pump liner that looks like it houses a pump? Introducing the patent pending 1-800-Busy Dog Basement Technologies® Water Grabber® Bull Dog™.



Revolutionary

Standard Water Grabber® Bull Dog™ with single pump and top discharge with Ranger™ drain.



Revolutionary

Water Grabber® Bull Dog™ with two pumps and top discharge.

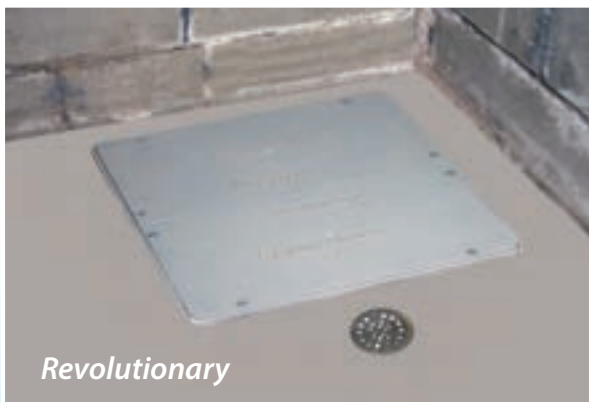

Revolutionary

Water Grabber® Bull Dog™ with solid lid, hidden pipes and wires.



James Pratt
President & Founder
Busy Dog



Your home deserves beauty and function from top to bottom ... who wants a sump pump to look like a sump pump?

1-800 Busy Dog Basement Technologies® is proud to introduce our revolutionary new Water Grabber® - the "Bull Dog™"! Our unique patent pending sump pump system represents an innovative alternative to the common circular or "open pit" pumping unit. Our "liner" which houses the pump in and under the ground has a SQUARE lid! 1-800-Busy Dog Basement Technologies® research and development department continues to "think outside the box"; and in this case, "inside the box" and as a result ... the new Water Grabber® Bull Dog™ has arrived!

The pumping unit that does not look like a pump.



Side View

"Cut away" view of the Double Bull Dog™ configuration with a Stallion Battery Backup and sealed lid. One pump is raised above the other on a patent pending special interior shelf with the pipes hidden.

Most people are familiar with the old circular design of sump pumps or "open pits" that other waterproofing companies seem content to use. Basement Technologies recognizes that to be a leader in the basement waterproofing industry, one must continually improve old products and introduce more efficient new ones.

The circular pump liner or "open pit" is simply not as aesthetically pleasing or as effective as our new liner ... Our answer to this out-of-style look and function is the Water Grabber® Bull Dog™.

Your basement was built square, level, and plumb - not circular, so why have a circular liner in a square corner which looks like a plumbing product?

Historically, a sump pump is located on a straight wall or in a corner. Doesn't it make sense to install a sump pump that fits snugly and attractively in your basement ... and emulates a building product look? - not a sump pump!

Why would we call our revolutionary new product the Bull Dog™?

... because that's exactly what it is! The Bull Dog breed combines characteristics like tenacity, loyalty, toughness and veracity ... all of which define our new patent pending sump pump with the added benefits of backups and secondary pumps and configurations ... this all can be accomplished without round liners or having ugly "buckets" that look like sump pumps.



Outdated



Revolutionary

A typical 1-800-Busy Dog Basement Technologies installation. Shown with top discharge and our Ranger™ drain.

The most effective waterproofing systems are installed in the inside of the home. When interior drainage systems are installed, they need a central ejection device – a way to get the water from the basement to the outside of the home. Our patent pending Water Grabber® Bull Dog™ is the heart and lungs of our Water Trek Aqua Route® perimeter system. The Water Grabber® Bull Dog™ consists of a patent pending drilled polyethylene basin with a split or solid lid. We use 3/4" gravel to surround the basin and help filter the water. The pumping device is a 1/3, 1/2 or 3/4 H.P. cast iron pump rated at approximately 3,000 - 4,200 gallons per hour and will pump up to 1/2" solids.

Independent and company tests indicate that this pump is the best in the industry.

We install our alarm, the Grabber Pal™, in the basin to alert you if the pump has a mechanical problem or was unplugged accidentally. This alarm is float activated and far superior to sensor type alarms which other companies carry. We use a special rubber fitting called the Silencer™ over or under the lid dependent on a side or top discharge to muffle the already quiet pump. We normally discharge the water to the exterior lawn, approximately 10 to 20 feet from the base of the home, to our special Bubbler Pot™ or underground to our Lawn Magnum®. We always install our patented Freeze Stop™ discharge line protector, with 360° of protection, to guarantee our sump pump discharge line will always discharge to the outside and never back up.

Do you want a sump pump in your basement that looks like a sump pump?

The perception of potential home buyers is "sump pumps are ugly". 1-800-Busy Dog Basement Technologies® new patent pending unique design hides your pump in a liner that is extraordinarily attractive. The liner is the "housing" that holds our superior pumps under the ground.

There are none like it in the basement waterproofing industry and no other basement waterproofing company can offer a sump liner like it!

ASK YOUR REPRESENTATIVE ABOUT OUR 3 PUMP REDUNDANT SYSTEMS, AND OUR 12 PUMP CONFIGURATION OPTIONS...

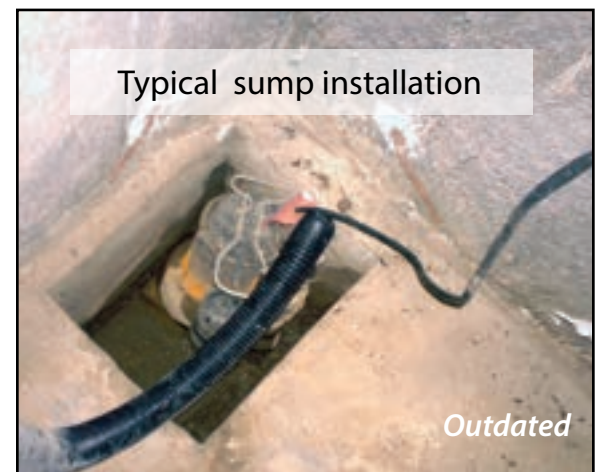

The neat and clean look of the Water Grabber® Bull Dog™ with a Stallion Eliminator Battery Backup, side discharge and Ranger™ drain.

Is your pump outdated?

Our patent pending Water Grabber® Bull Dog™ revolutionary liner ... the “no sump pump look”.

The most innovative design change the industry has experienced... and the Water Grabber® Bull Dog™ is adaptable to several pump configurations. The built in sump stand at the bottom of the liner virtually eliminates stone and dirt infiltration through the pumping unit. An optional raised stand for a secondary pump is also available. Our new patent pending Water Grabber® Bull Dog™ offers virtually unlimited options for pumps and backups.

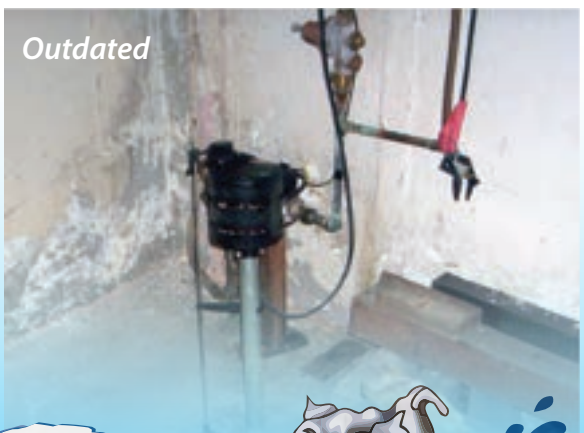

The neat look of a Double Bull Dog™ Side Discharge/Double Pump solid lid. Added security and neat “no sump” look.

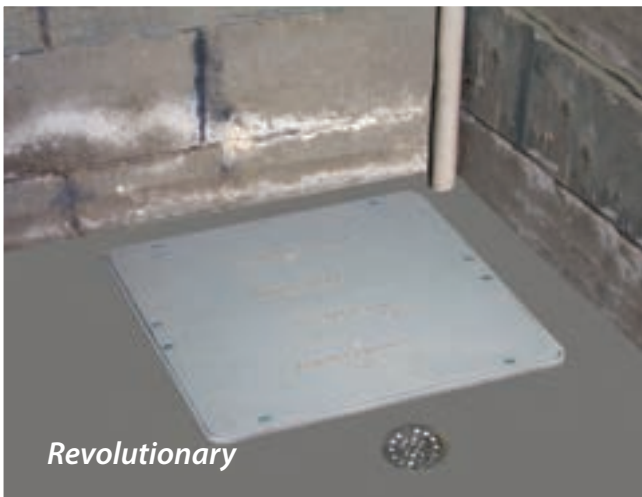

Classic Bull Dog™ with side discharge. Sealed solid lid for easy “hiding” under carpet or flooring.



One On One There Is No Comparison...
Available Sump Pump Liners For Basement Waterproofing Systems

PRODUCT COMPARISONS



Retail (Hardware Center) Sump Pump Liner



Sump Pump Liner



Sump Pump Liner



Sump Pump Liner



Sump Pump Liner



Water Grabber® Bull Dog™ Sump Pump Liner

Sump liner can be purchased anywhere. Looks like an open sump pit and holder.

Sump liner can be purchased from manufacturer directly. Looks like a sump pump holder.

Sump liner can be purchased by manufacturer's reps only. Looks like a sump pump holder.

Sump liner can be purchased by manufacturer's reps only. Looks like a sump pump holder.

Sump liner can be purchased directly. Construction weak-very shallow and not able to handle large volumes of water. Side pipe discharge hard due to shallow pit.

Sump liner can be purchased by manufacturer's reps only. Does not look like sump. Pump looks neat and square.

Liner may or may not have inlets for water. Lid not sealed allows gas, rodents and insects into basement.

Liner may or may not have inlets for water.

Liner has inlets for water. Sealed lid.

Liner has inlets for water. Sealed lid.

Inlets too big. Influx of water can overwhelm pump. Allows stone in. Manufacturer supplies "mesh" product to stop stones and debris.

Liner has inlets for water. Sealed lid only. Specialty contractor must install. Must be certified by company-intense training.

Does not have inlet for system. Has to be field cut.

Does not have inlet for system. Has to be field cut.

Has special fitting to allow water into sump liner from perimeter system.

Has special fitting to allow water into sump liner from perimeter system.

Does not have inlet for system. Has to be field cut. Liner is shallow - easily overwhelmed.

Has special fitting to allow water into sump liner from perimeter system.

Can be installed by anyone. Possible underexcavating of dirt under footing.

Can be installed by anyone.

Installed by manufacturer's representative only. Can also be obtained through certain plumbing suppliers.

Installed by manufacturer's representative only.

Can be installed by anyone. Liner is shallow allowing large volume of water in at once - pump easily overwhelmed. Can allow dirt in from under footing.

Installed by manufacturer's representative only. Under excavation of footing unlikely due to size of holes and system's custom design.

Can house multiple pumps. No stands available.

Can house multiple pumps. No stands available.

Can house two pumps. Manufacturer supplies custom stands.

Can house three pumps. Manufacturer supplies custom stands.

Only one primary pump may be installed in liner. Battery backup just fits - too high and easily overwhelmed.

Can house multiple pump setups. Custom stands inherent and supplied by manufacturer.

SUMMARY

- Can be installed by any non-professional
- Looks like an ugly open sump pit
- Gas, rodents & insects can enter living area
- No stands available for multiple pumps

SUMMARY

- Can be installed by any non-professional
- Looks like a sump pump holder
- No stands available for multiple pumps

SUMMARY

- Mfg. reps only can install
- Can house 2 pumps
- Stand available
- Inlets for system
- Looks like a sump pump holder

SUMMARY

- Mfg. reps only can install
- Can house up to 3 pumps
- Stands available
- Inlets for system
- Side discharge not standard
- Looks like a sump pump holder

SUMMARY

- Anyone can purchase
- Inlets too big. Use of mesh to compensate for "milk crate" construction
- No inlets for system
- Too shallow - can easily be overwhelmed
- Looks like a milk crate in floor.

SUMMARY

- **Square, level and plumb**
- Unit does not look like a pump holder
- Fits perfectly in corner
- **Blends** with color of floor
- Pumps & Backups available
- **Special holes** to accommodate perimeter system
- Can only be installed by qualified "licensed" dealers
- **"No pipe"** look available
- **Sealed lids**

Beauty Is In The Eye Of The Beholder...Behold!!!

Square, level and plumb are how homes are built. We think the liner should look just as handsome as your home and not like a plumbing (circular) fixture.



Specially made only for Basement Technologies Dealers and our customers.

Rigid high density polyethylene injection molded to be stronger and more durable than structural foam which most others use.



Sealed lid Water Grabber® Bull Dog™ with Ranger™ drain. The Ranger™ drain can handle pipe bursts and funnels directly into our liner.



Sealed lid for top or side discharges. Our lids are colored gray to match the concrete on the floor and able to be sealed tight eliminating radon gas, rodents and insects from entering your living space. Side discharges often are excellent to accommodate for carpet or flooring being placed over the top.



Predrilled holes in side of liner smaller than the surrounding gravel keep stones and debris out of your liner and away from the pump.



Lid can support upwards of 450 lbs. Excellent to install carpet or flooring directly over.



3" knockout to accommodate 3" pipe that houses wires for a sealed lid Water Grabber® liner.

4" knockouts to accommodate the Water Trek Aqua Route® to Water Grabber® connectors to drain the perimeter system directly to our liner. Colored gray to match your floor.



Top shelf enables our unit to house 2 pumps in the same liner. Redundancy is key for waterproofing. We can install 3 pumps - 2 primaries and 1 backup and also offer D/C backups for the primary pumps creating a virtual 5 pump system.

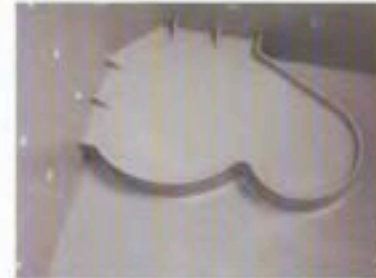

Shelf for bottom of liner that raises the pump about 1-1/2" to help ensure dirt does not "clog" our pumping unit.



1-1/2" cutouts to accommodate 1-1/2" discharge line for a sealed lid and another for the Ranger™ drain mounted (countersunk) in the concrete to drain water if a pipe bursts in the basement.

Square, level and plumb are how homes are built. We think the liner should look just as handsome as your home and not like a plumbing (circular) fixture.



Others try to copy, but fall short.



Basement Technologies uses only the best. Bell & Gossett pumps are used in our Water Grabber® Bull Dog™ liner.



Heavy duty Stallion Eliminator Battery Backup Unit uses a third pump in our liner. With additional direct current backups has five pump capability.

Comprehensively The Best Pumping Unit & Holder In The Industry...There Are No Comparables!!!
Improving Basement Waterproofing From The Ground Up™

WATER TREK AQUA ROUTE®

**1-800-Busy Dog
Basement
Technologies**
The Basement Specialists™
Basement Waterproofing



The Water Trek Aqua Route® basement waterproofing system is simply ...

... the most effective system on the market today – bar none!

The Water Trek Aqua Route® system is a unique patented system that can be “custom tailored” to each basement water problem and footing configuration under the floor. It addresses water from both sides of the footing and can be installed in any soil or subfloor situation. Trust your home to the leading name in basement waterproofing ...

1-800-Busy Dog!

1-800-Busy Dog Basement Technologies® routinely installs waterproofing systems in finished and unfinished basements and is the fastest growing basement waterproofing network of dealers in the world. **With 1-800-Busy Dog Basement Technologies® “custom tailored” patented system solutions comes total peace of mind!**



Experts agree the most effective basement waterproofing method is an interior sub floor system. The Water Trek Aqua Route® is the best product available.

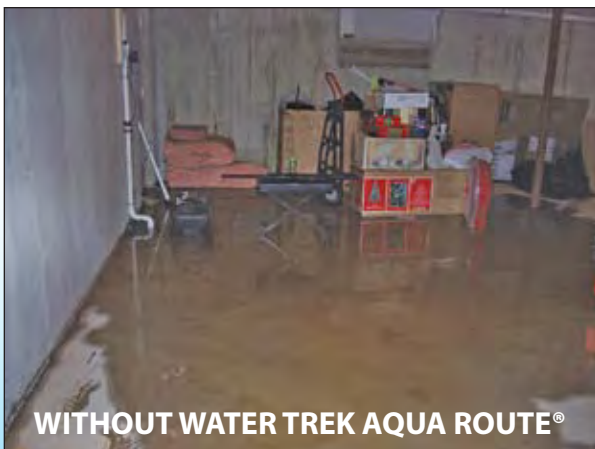

www.1800busydog.com®



Rest easy...Water Trek Aqua Route®

Your "peace of mind" Water Trek Aqua Route® system will be designed and engineered by a 1-800-Busy Dog Basement Technologies® System Technician and installed by a fully trained Installation Team. 1-800-Busy Dog Basement Technologies® has installed and continues to install our patented Water Trek Aqua Route® system in thousands of homes throughout North America, Canada and Europe.

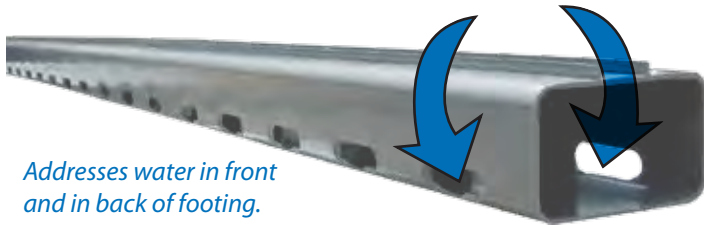

Addresses water in front and in back of footing.

Independent and company research testing prove that basement water threatens entry to the living space from in front of the footing, as well as from the footing/foundation wall seam. The Water Trek Aqua Route® conduit has slots on both sides to accommodate both problem areas.

Soil composition, along with footing, wall and floor construction vary greatly from one house to another. It is virtually impossible to analyze any soil and footing configuration until the floor is opened.



Floor grate at bulkhead door ties into system.

Identifying the footing configuration in relation to the floor (slab) and the foundation wall is the key to installing a waterproofing system that will last for the life of your home. Our fully trained 1-800-Busy Dog Basement Technologies® Design Technicians and Installers play a critical role in warranting that your basement stays dry forever.

"The generic 'one size fits all' waterproofing system that other companies offer motivated me to invent a better waterproofing system that addresses any water problem and can be custom tailored to the homeowner's specific needs dependent on their soil, footing and construction type." – James Pratt, Founder

Your home is your most valuable asset ... and each home and basement are different. The patented Water Trek Aqua Route® system is engineered with two (2) unique components. This design enables your 1-800-Busy Dog Basement Technologies® representative to address and solve any sub-floor problem with a "custom tailored" solution and effective basement waterproofing system.

The Water Trek Aqua Route® system is uniquely adaptable and can accommodate all six (6) possible footing configurations. Our exclusive, versatile, "no-clog" adjustable depth system delivers a "peace of mind" permanent solution to your basement water problem and is designed to fit all footing configurations.

Identifying footing configurations prior to installation is imperative for a successful outcome to any basement waterproofing project.



TYPICAL FOOTING CONFIGURATION
One of six possible configurations under your floor.

Custom Tailored Waterproofing®

Patented for a reason ... **It just works better!**

1-800-Busy Dog Basement Technologies®' Water Trek Aqua Route® is a two-piece system. The various designs hug walls and channel water from the wall above and the footing below to the sub-floor Water Trek Aqua Route® system below the floor.

It can create a virtual airtight fit on most, if not all, foundations eliminating potential radon gas, sub floor smells or insects from entering the living space. We have five (5) different Cove Base options, each designed to fit and be custom tailored to your basement.

After installing a full perimeter Water Trek Aqua Route® system, you can rest assured that your basement will be dry forever – **it's warrantied!**

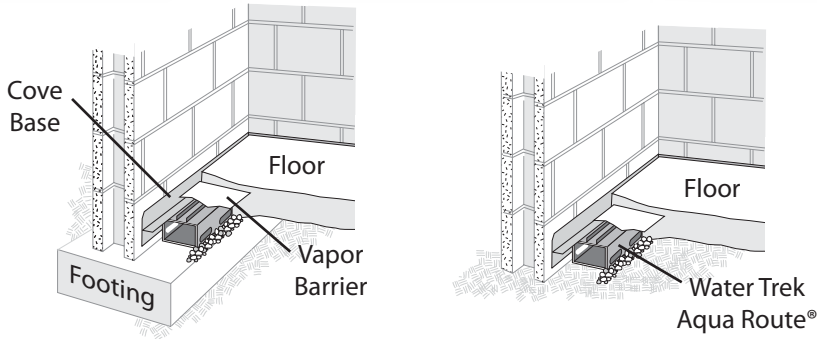

TYPICAL CONFIGURATION

NO FOOTING

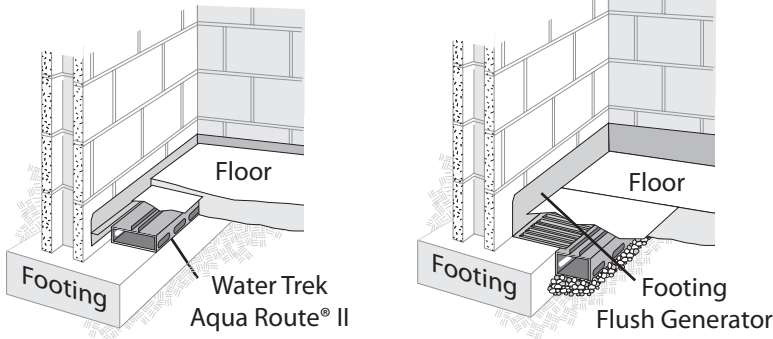

LESS THAN 2 3/4" CONCRETE

FOOTING FLUSH W/FLOOR

FOOTING CONFIGURATIONS



The patented Alternator® with Freeze Stop®



The standard Water Grabber® Bull Dog™ top discharge and the optional side discharge. The patent pending sump that does not look like a sump.



The Bubbler Pot™



The patented Freeze Stop®

Please ask your 1-800-Busy Dog Basement Technologies®' representative for more details on our other great waterproofing products.

“Rest easy! Basement Technologies did the job.”™

Custom Tailored Waterproofing.®

Technicians are thoroughly trained in classroom theory and installation guidelines to ensure waterproofing success in each basement.

All 1-800-Busy Dog Basement Technologies® design and installation technicians have extensive industry experience and receive comprehensive classroom and field training at our National Supply and Dealer Training Center in Massachusetts. The 1-800-Busy Dog Basement Technologies® team is customer driven and provides quality work that is second to none!



Training and more training

Classroom theory, troubleshooting and diagnosis are regular activities for all employees and dealers.



"Hands On" training is critical for excellent customer service. 1-800-Busy Dog Basement Technologies® technicians and dealers are required to undergo hours of technical and ethics training.

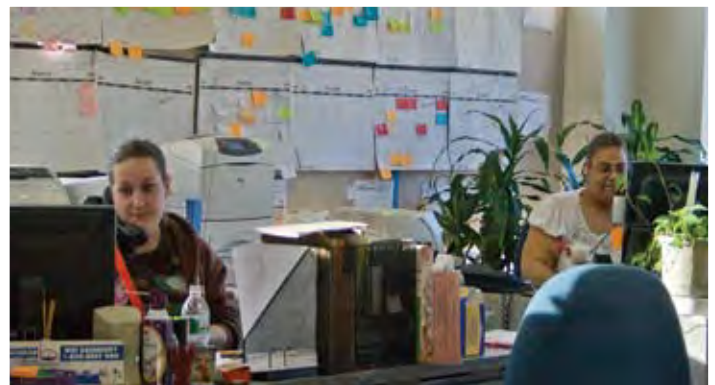

Customer service

"Understanding the problem and fixing it intelligently with constant communication to the customer during each project is the cornerstone of our company. We will settle for nothing less than 100% customer satisfaction." – James Pratt

Trust your home to the leader in the basement waterproofing industry –
1-800-Busy Dog Basement Technologies®.

Improving Basement Waterproofing From The Ground Up™

www.1800busydog.com®

